

# Pearl®

2016 GENERAL CATALOG





# Pearl

## 2016 GENERAL CATALOG

All specifications and availability subject to change without notice.

### DRUM SETS

- 8-11 Masterworks
- 12-13 Reference
- 14-15 Reference Pure
- 16-19 Music City Custom
- 20-21 Masters Maple Reserve
- 22-23 Masters Maple Complete
- 24-25 Session Studio Classic
- 26-27 Wood-Fiberglass
- 28-29 Crystal Beat
- 30-31 Decade Maple
- 32-33 Export / Export Lacquer
- 34 Midtown
- 35 Roadshow
- 36-39 ePro & Accessories
- 40-43 Pearl Artists

### SNARE DRUMS

- 44 Reference
- 45 Series Component
- 46 Free Floating
- 47 Hybrid Exotic
- 48 SensiTone
- 49 SensiTone Premium
- 50 Signature
- 51 Effect

### HARDWARE

- 52-53 Demon Drive
- 52-53 Demon Chain
- 54-55 Eliminator Redline
- 56-57 P930 / P932
- 58-59 Hi-Hat Stands
- 60-61 Snare Stands
- 60-61 Drum Thrones
- 62-63 Boom/Straight Cymbal Stands
- 64-65 Racks & Tom Stands / Arms

### PERCUSSION

- 66-67 Signature Congas & Bongos
- 68-69 Cajons & Accessories
- 70 Timbales
- 71 Cowbells
- 70-71 Frame Drums & Accessories
- 72 Djembes & Folkloric Percussion
- 73 Brazilian & Concert Percussion
- 74 Hand Percussion
- 75 Percussion Stands, Bags & Holders
- 76-77 Replacement Parts
- Back Configuration & Color Chart
- Cover

### THE BEST WARRANTY IN THE INDUSTRY! \*

#### COMMITTED TO THE HIGHEST LEVEL OF CUSTOMER SATISFACTION.

The Pearl Lifetime Warranty is a statement of confidence to our customers to the reliability of Pearl products. Pearl drums, stands and hardware are designed and manufactured to the highest standards in quality, style, appearance and playing performance. This lifetime warranty reflects a tradition of excellence and a commitment to superior engineering and craftsmanship dedicated to you, the drummer. The Pearl lifetime warranty is our pledge to you that we will proudly stand behind our product for as long as you own it. *Buy it once, play it for life.*



- Drum Set/Concert wood and metal shells for the Lifetime of the Original Owner.
- Foot pedals, hi-hat stands, cymbals stands, boom cymbal stands, snare drum stands, throne bases, floor-standing tom stands, floor-standing cymbal/tom stands, concert stands, racks and rack accessories, cymbal holders and multi-clamps for the Lifetime of the Original Owner. Some exceptions apply.
- Drum Set claws, tension rods, swivel nuts, spurs, tom brackets, tom holders, strainers, and nuts and bolts for the Lifetime of the Original Owner.
- Rotationally molded cases for the Lifetime of the Original Owner.
- The LIFETIME WARRANTY applies to the aforementioned Pearl products purchased from June 15, 2009.

\* This warranty is valid only in the United States and excludes the Crystal Beat and Roadshow Series.



From our humble beginnings in 1946 to our worldwide network of drums and drummers 70 years later, Pearl's family owned-and-operated tradition of innovation and personal service continue forward to give a percussive voice to every player.

Here are some highlights of our seven decade journey:



- April 2, 1946:** Katsumi Yanagisawa starts Pearl with two employees in 300 sq. ft. factory in Sumida, Japan, making music stands and accessories.
- 1950:** Recognizing an emerging market, Katsumi shifts focus to manufacturing drums.
- 1953:** Pearl Musical Instruments enjoys rapid growth in Japan, expanding to over 30 employees for producing basic drum sets, marching and concert drums, and accessories.
- 1957:** Katsumi's eldest son Mitsuo forms an export division to meet international demand.
- 1961:** Pearl expands by building a 15,000 sq. ft. manufacturing facility in Chiba, Japan. Pearl World Headquarters remains in Chiba to this day.
- 1965:** Pearl's long-range plan to increase in product variety and development includes a new series of professional drum sets, expanded worldwide distribution, and unparalleled support.
- 1966:** President Series professional drums are launched in Japan. Their unique Phenolic shell design and sound catch the ear of touring pro's such as Art Blakey and JC Heard.
- 1973:** Pearl expands drum production to a second 93,000 sq.ft. production facility in Taichung, Taiwan. Wood-Fiberglass hybrid drums are debuted, and Pearl USA opens in Nashville, TN.
- 1974:** Crystal Beat seamless acrylic drums are introduced. Pearl USA welcomes a host of high-profile artists including Peter Criss, Louis Bellson, Ed Shaughnessy, and Larrie Londin.
- 1976:** Pearl develops its first all Maple drum kit, the Giant Step, for the Japanese market.
- 1977:** Peter Criss tours the Pearl drum factory in Chiba during KISS' first tour of Japan.
- 1978:** Giant Step series expands with fiberglass-lined Maple drums, solidifying Pearl's reputation as a top percussive innovator. The Patented Vari-Set gearless tom holder is released.
- 1979:** Pearl advances electronic percussion with the introduction of the Syncussion SY1 drum synthesizer.
- 1981:** Pearl introduces its "Blues Flavor" series drums featuring 100% Birch shells.
- 1982:** "Toto IV" is released with new Pearl artist Jeff Porcaro on the drums. Phil Collins debuts "In the Air Tonight" live behind his new Pearl all Birch kit.
- 1983:** USA-made Criterion Marching Drums signal Pearl's first entry in marching percussion. The Free-Floating Snare Drum and the Jeff Porcaro-designed Pearl DR1 drum rack are launched.
- 1984:** Innovation shifts into high gear at Pearl Taiwan with the production of MX, MLX, and GLX pro Maple drums. Export Series becomes the drum set choice of a generation of players.
- 1985:** Pearl's Drum-X System presents the next phase of electronic drums.
- 1986:** Pearl's first double bass drum pedal (P850TW) debuts along with 800 and 900 Series tour-grade hardware. Syncussion X electronic drums take e-synthesis percussion a step further.
- 1987:** The biggest names in rock play Pearl as Prestige Custom (MLX Maple) and Studio (BLX Birch) are launched. Tommy Lee's "Spinning Drum Solo" defies gravity in arenas worldwide.
- 1988:** Drummer Steven Adler drives Guns n'Roses from clubs to arenas with Pearl.



- 1989:** Pearl's groundbreaking Zenithal Resonator (CZX) 8-ply thick Maple shells debut worldwide in stunning Champagne Birdseye finish, setting a standard as the next level in pro drums.
- 1990:** Masters Series Maple (MMX) and Birch (MBX) drums raise the bar for the pro player. Pearl Corporation's expanded USA Headquarters in Nashville, TN open at its current home on Metroplex Dr. Pearl's first FFX Marching Snare drum sets a new standard for Field Percussion.
- 1992:** Pearl hand percussion products begin under the Afro Percussion name.
- 1993:** Session Series is launched.
- 1994:** Forum Series debuts, offering more to the entry-level player than ever before.
- 1995:** Export becomes the best-selling drum set of all time with over one million drums sold worldwide. Marvin "Smitty" Smith begins his 15-year tenure on "The Tonight Show."
- 1996:** Pearl's 50th Anniversary Ltd. Edition Solid Maple snare, Signature snares for Chad Smith, Omar Hakim, J.R. Robinson, and Dennis Chambers, and Powershifter pedals are introduced.
- 1997:** Masters Mahogany Classic (MHX) and Sensitone snare drums are developed.
- 1998:** Pearl redefines the scope of customized drums with Masterworks. Symphonic snare drums are introduced.
- 1999:** The OptiMount tom suspension system is developed. Pipe Band marching snares debut, as well as new Signature snares for "Smitty" Smith and Steve Ferrone.
- 2000:** The Powershifter Eliminator's patented Interchangeable Cam System brings customized feel to bass drum pedals. The Pearl Drummer's Forum is launched to players around the globe.
- 2001:** Pearl Percussion makes a grand entrance at NAMM 2001. Tico Torres' custom U.S. Flag-painted Masters kit – played at the Concert for NYC with Bon Jovi – is auctioned off to benefit 9/11 victim relief.
- 2002:** More Signature Snare Drums from Ian Paice, Tico Torres, and Eric Singer. Eric and Tico (with KISS and Bon Jovi) play the closing ceremonies of the 2002 Winter Olympics.
- 2004:** Masakatsu, the third generation of the Yanagisawa family, becomes Pearl CEO.
- 2006:** Pearl artist Mike Mangini becomes the World's Fastest Drummer by breaking the world record for the most single-stroke hits (1,203) in one minute.
- 2005:** Reference Series drums launch following two-years of sonic testing and win the Musikmesse International Press Award for Best Drum Set.
- 2007:** Pearl introduces its unparalleled Lifetime Warranty on drums and hardware. Vision Series, the first drum series from Pearl's new China facility, are launched.
- 2008:** Masters (MCX) Maple's low price tag makes the professional drum kit attainable.
- 2009:** The Demon Drive pedal takes bass drum pedal performance to new heights, wins multiple Music Industry awards.
- 2010:** ePro Live, Pearl's electronic drum powerhouse, fuses real drum shells with TruTrac technology. Joey Jordison is voted "Best Drummer" by Rhythm Magazine. Mike Mangini joins Dream Theater.
- 2011:** Reference Pure's reduced-weight shell recipe debuts for the pro player. The Airframe Carriers' lightweight rugged design changes the playing field for marching percussion.
- 2012:** Session Series returns with a more affordable pro drum package.
- 2013:** Pearl brings back the best-selling drum set of all time with a completely redesigned Export Series kit. The Demon Chain pedal and redesigned Advanced Hardware System stands debut.
- 2014:** 28 new state-of-the-art snare drum models are launched, Crystal Beat seamless acrylic drums return and win NAMM Best In Show and DRUM Magazine Reader's Poll Awards.
- 2015:** Wood-Fiberglass drums are updated and reissued for the modern player, Chad Smith designs the three-section Tricolon Signature Snare.

# THE CHOICE IS YOURS.

PEARL HAS BEEN CRAFTING PERCUSSION INSTRUMENTS DESIGNED TO FIT THE NEEDS OF EVERY DRUMMER SINCE 1946. NO MATTER WHERE THE PLAYING ROAD TAKES YOU, PEARL HAS THE RIGHT DRUM SET OPTIONS TO MAKE YOUR VOICE HEARD AT EVERY STEP ALONG THE WAY.

## MASTERWORKS



### CUSTOM CRAFTSMANSHIP FOR THE MASTER PERCUSSIONIST.

The dream destination for the Pro drummer that wants true control. Every element of the kit's sound, look, and feel is player-selected from a limitless palette of custom options. Hand-crafted to heirloom perfection for the ultimate custom drum statement.

PAGES 8 - 11

## REFERENCE



### SONICALLY SELECT DRUM PERFORMANCE.

The best custom options from the Masterworks realm, preselected to draw the best in sound and playability from each drum. Optimum pro performance for high-volume, high-capacity playing presence.

PAGES 12 - 13

## WOOD-FIBERGLASS



### VINTAGE HYBRID, MODERN PERFORMANCE.

Saluting the sound that defined an era, a true Pearl original returns with our premium 7-ply Kapur shell, fused with a layer of hand-applied Fiberglass. The result is a unique combination of warmth, projection, and focused decay.

PAGES 26 - 27

## CRYSTAL BEAT



### THE ORIGINAL SEAMLESS ACRYLIC DRUM SHELL.

Originally introduced in 1973, Crystal Beat returns with unparalleled tonal - and visual - clarity and punch for a new breed of power players. Precision-molded in a variety of available sizes and finishes for an unmistakable drumming signature.

PAGES 28 - 29

## REFERENCE PURE



### UNRESTRICTED TONAL RESPONSE.

The sonically-select Reference formula in a thin drum shell format. Unrestricted tone for close-field articulation with a warm, resonant vibe. Ideal for controlled environments and concert settings where extended tuning range is paramount.

PAGES 14 - 15

## MASTERS MAPLE RESERVE



### A CLASSIC FORMULA FOR SONIC GREATNESS.

Combining a thin 4-ply Maple shell with 4-ply re-rings delivers an essential tonal combination of rich lows and wide-open resonance. This lively sonic character makes Masters Maple Reserve a natural choice for the most discerning musical pallet.

PAGES 20 - 21

## DECADE MAPLE



### A DRUM KIT 10 YEARS IN THE MAKING.

Pearl's 70 years of drum craftsmanship culminate with the kit you're ready to step up to. With 5.4mm Maple shells, pro-level features, and gorgeous lacquer finishes, Decade elevates your performance at a price that was previously impossible.

PAGES 30 - 31

## EXPORT / EXPORT LACQUER



### THE LEGENDS OF TOMORROW, PLAY EXPORT TODAY.

The kit that spawned a thousand drumming legends is back for a new generation. Available in wrapped or lacquer finishes, Pearl's new Export is built stronger than ever to give the student drummer's lifetime of play a strong beginning.

PAGES 32 - 33

## MASTERS MAPLE COMPLETE



### THE MASTERS SHELL COMES FULL CIRCLE.

The road-proven combination of warmth, power, and tonal purity that made Masters a legend shines forward. Pearl's new EvenPly 6-layer premium Maple shell, 2.3mm Superhoops, and an improved price tag make Masters a must for the touring pro.

PAGES 22 - 23

## SESSION STUDIO CLASSIC



### THE ESSENTIAL SOUND OF STUDIO GROOVE.

Classic, articulate, controlled. The punchy attack and tonal clarity of Session series' influential sound is here to stay with Kapur/Birch hybrid shells, traditional sizes, and a host of premium lacquer finishes.

PAGES 24 - 25

## MIDTOWN



### BIG GIG, SMALL RIG, HUGE SOUND.

For full-size play in a smaller footprint, this ultra-portable, complete shell pack lets the gigging drummer on the move sculpt rich, powerful grooves. Essential gear for the metropolitan player.

PAGE 34

## ROADSHOW



### IT'S YOUR TIME TO PLAY. START THE RIGHT WAY!

The rhythm is in you; the right gear is essential for setting it free. The Roadshow complete drum set package comes with everything needed (drums/hardware/cymbals/extras) to start your rhythmic journey to the big time.

PAGE 35

# MASTERWORKS

CUSTOM CRAFTSMANSHIP FOR THE MASTER PERCUSSIONIST.

SHELL THICKNESS PRECISION TONAL CONTROL



**THIN** (4-ply, 5mm w/ 4-ply Reinforcement Rings)  
Responsive tonal sustain for the near-field environment.



**MEDIUM** (6-ply, 7.5mm)  
Exceptional for general-purpose play. Excellent projection with full-bodied wood tone.



**THICK** (8-ply, 10mm and 10-ply, 12.5mm)  
Maximum cut and projection with subdued sustain.

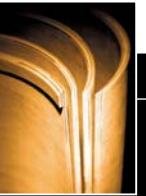

Masterworks allows you to further tailor your drum tone by selecting the thickness of each shell.



**YOU'VE ARRIVED.  
IT'S TIME TO TELL THE WORLD.**

Since 1999, Pearl's hand-crafted *Masterworks* drums have given the professional drummer the tools to make a totally custom statement with new heights of perfection.

## SHELL MATERIALS LET YOUR EARS DECIDE

For a totally personal sonic signature, Masterworks has more options for shell composition than any other custom drum builder; making each drum a truly unique work of art.

### MAPLE

*The perfect blend of tone, attack, and body.*

- North American hardwood with rich, even grain.
- Ideal for general purpose applications.
- Equal tonal amounts of hi-end attack, mid-range body, and low-end punch.

### BIRCH

*The precision choice for high-volume cut and power.*

- Premium "white" wood with marbled, subdued grain.
- Boosted hi-end and mellow midrange excellent for stage and studio.
- "Built-in EQ" delivers articulate stroke with shorter, even decay.

### MAHOGANY

*Deep, powerful punch with dark, elegant tone.*

- Porous African wood with rich, dark texture and grain.
- Boosted bottom-end perfect for controlled rooms/studios.
- Rich low-end warmth with beautifully smooth midrange and hi-end roll-off.

### COMPOSITE SHELL

*Custom configure the Ultimate Hybrid.*

- Combine wood types to sonically blend the characteristics of each material
- Maple/Birch ideal for outer plies for ease of finishing, while inner Mahogany plies boost bass and low end punch.
- Each cross-laminated two-ply panel is hand-selected for proper density, grain consistency, and color.

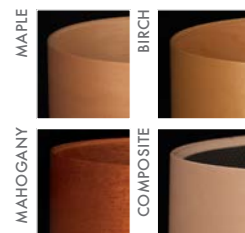

## CUSTOM SHELL INTERIORS Expand the Tonal Spectrum.

- **Fiberglass** – A true Pearl original, a layer of fiberglass can be hand-applied to shorten decay and add volume
- **Carbonply** – A thin layer of carbon fiber can be fused to any shell interior to maximize high-frequency response.

- **Artisan Veneers** – Now any of Pearl's exotic exterior hardwoods can be added to the inner ply for further tonal expansion

#377 SCARLET SPARKLE FADE  
w/ HALOFLAKES

**Define Yourself.** Masterworks truly represents all that is possible in custom drums. Allowing you the freedom to custom configure your perfect visual statement, Masterworks' virtually unlimited lacquering options range from Gloss, Oil, and Satin finishes to Transparents, Fades, and Bursts. Custom graphics, banding, and inlay striping - All possible over your choice of hand-matched exteriors or Artisan exotic veneers.

NO ASSEMBLY LINE. NO BOUNDARIES.



### BEARING EDGE OPTIONS

Nothing influences a drum's overall response more than the bearing edge. That's why Masterworks gives you three bearing edges from which to choose, and with our new hybrid option, allowing you to mix edge types on batter and resonant side of the same drum.



**45 DEGREES**  
Provides the perfect blend of attack and warmth.

**ROUNDED 45**  
Boosts mid to high frequencies as a result of greater head-to-shell contact.

**FULLY ROUNDED**  
Provides maximum head-to-shell contact for the greatest boost in mid to low range frequencies.

### HARDWARE COLOR AND LUG OPTIONS

Masterworks Series drums feature a choice of drum hardware plating options, and can be custom configured with any one of our precision tuning lugs.



**CHROME**  
(Shown w/ STL100 Lug)

**NICKEL**  
(Shown w/ STL150)

**GOLD**  
(Shown w/ STL150 Lug)

**BLACK CHROME**  
(Shown w/ BRL100 Lug)

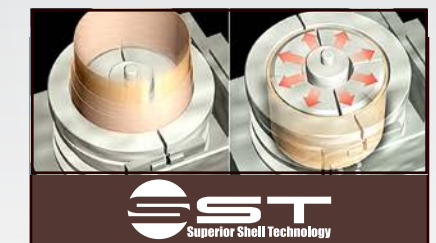

### ASSURES MANUFACTURING EXCELLENCE. EVERY TIME.

Pearl's proprietary Superior Shell Technology begins with select woods chosen for their unique acoustic attributes. Each is milled to precise thickness with overlapping scarf joint seams, and saturated with Pearl's exclusive "AcoustiGlue"; creating optimum resonance by drying to the exact consistency of the wood. Finally, the plies are cross-laminated in high-temperature molds at 1000 PSI of hydraulic pressure, producing superior tone and extreme strength.



BUBINGA  
NATURAL TO WALNUT BURST

# REFERENCE SERIES

SONICALLY SELECT DRUM PERFORMANCE.

Of the many Reference Series snare drums available, our Reference Series wood snare drum uses 6 inner plies of Birch united with 14 outer plies of Maple for a staggeringly thick 20 ply shell. The 45 Degree bearing edge brings all 20 plies to the party in a highly focused sweet spot. This projects the volume that you would expect from such a thick shell without losing sensitivity or articulation.

REFERENCE 20 PLY  
Sn rum

Bridge style lugs and floor tom leg brackets provide maximum resonance with minimal shell contact. Pearl's revolutionary BRL lugs assure the ultimate in head seating and tuning integrity. The unique swivel function assures maximum resonance and sustain.

Our telescoping bass drum spurs feature a high-grip rubber tip. The tip can retract and allows a recessed spike to be exposed for maximum "bite" on carpeted surfaces.

## REFERENCE SERIES: THE STANDARD TO WHICH ALL DRUMS ARE JUDGED.

Reference Series Drums are the product of what became a two and a half year search for harmonic perfection. Like keys on a piano, each drum in a kit should combine to create a singular instrument without losing its own sonic signature. With this concept in mind, Pearl explored the many options in the Masterworks crafting process to find the perfect combination of shell material, thickness, and edge profile for each individual size and type of drum. The result is a collective of individually-engineered drums dialed-in to the best sonic character for that drum's intended voice. Truly, the *reference standard for quality and sound performance.*



All Reference snare drums feature Pearl's SR1000 Glide-Lock Strainer, which includes a locking throw off lever and tension knob that won't loosen no matter how hard you play. Low-friction technology permits smooth gliding action for ultra quiet, super precise motion.

US Patent #7220905, #7301087, #7365256

### REFERENCE SPECIFICATIONS

SHELLS	Maple, Birch & African Mahogany
SNARE	20 Ply Matching 13 x 6.5, 14 x 5 or 14 x 6.5*
FINISH	Super High Gloss Lacquer / Lacquer Sparkles**
HEADS	Remo Clear Emperor Tom, Powerstroke3 Bass
TOM MOUNTS	Aluminum OptiMount Suspension System
TOM ARMS	Sold Separately
DRUM HARDWARE	Chrome, Nickel, Black Chrome Plated or Gold Plated
HOOPS	MasterCast Die-Cast Hoops
LUGS	BRL Bridge Lugs with Swivel Function

### THE REFERENCE RECIPE

All drums are not created equal. So why make them all with the same wood type and edge? Reference toms, snares, and bass drums each have a different 'recipe' for their specific application and voice.

THE REFERENCE RECIPE	SHELL TYPE	BEARING EDGE	SONIC OUTPUT
8" and 10" Toms	<b>Maple(4)/Birch(2)</b> 6-ply (RF 7.5mm / RFP 5.4mm)	Rounded 45°	Extra cut and projection for high-note pitch
12" Toms	<b>Maple(6)</b> 6-ply (RF 7.5mm / RFP 5.4mm)	Rounded 45°	Transitional mid-note; blend of warmth and cut
13" Toms	<b>Maple(4)/Mahogany(2)</b> 6-ply (RF 7.5mm / RFP 5.4 mm)	Rounded 45°	Top-end slap with added low/bottom end
14" and 15" Toms	<b>Maple(4)/Mahogany(2)</b> 6-ply (RF 7.5mm / RFP 5.4 mm)	Fully Rounded	Bracing low-end with extended sustain
16" Toms	<b>Maple(2)/Mahogany(4)</b> 6-ply (RF 7.5mm / RFP 5.4mm)	Fully Rounded	Bracing low-end with extended sustain

THE REFERENCE RECIPE	SHELL TYPE	BEARING EDGE	SONIC OUTPUT
14" Floor Toms	<b>Maple(4)/Mahogany(4)</b> 8-ply (RF 10mm / RFP 7.2mm)	Fully Rounded	Bracing low-end with extended sustain
16" and 18" Floor Toms	<b>Maple(2)/Mahogany(6)</b> 8-ply (RF 10mm / RFP 7.2mm)	Fully Rounded	Bracing low-end with extended sustain
18" and 20" Bass Drums	<b>Maple(2)/Mahogany(4)</b> 6-ply (RF 7.5mm / RFP 5.4mm)	Fully Rounded	Enhanced sub-frequency response
22", 24", and 26" Bass Drums	<b>Maple(2)/Mahogany(6)</b> 8-ply (RF 10mm / RFP 7.2mm)	Fully Rounded	Booming bass tone with articulate punch

\*Sold Separately \*\*See full Color Chart on back cover for all Special Order Finishes. Stock finishes listed right.



# REFERENCE PURE SERIES

UNRESTRICTED TONAL RESPONSE.

## THE REFERENCE PURE DIFFERENCE:

- Ultra-thin "Evenply" Shells (About 30% thinner than Reference) resonate freely with the lightest touch. We reduced the tom thickness from 7.5 to 5.4mm thick and floor toms and bass drums from 10mm down to 7.2mm.
- Shell hardware mass decreased by 30%, allowing better vibration transference to the shell from the head.
- 1.6mm FatTone Hoops' exclusive hemmed/welded edge (US Pat. #8367917) gives increased strength to low-mass design.
- STL Swivel Tube Lugs allow for increased resonance, minimal shell contact, and precisely aligned, no-bind tuning.

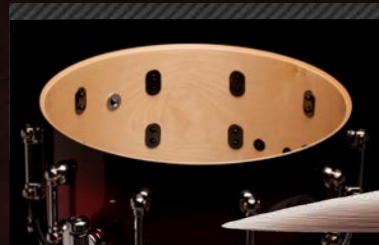

Reference Pure snare drums feature ultra-thin "Evenply" shells with 4 outer plies of Maple for a smooth, balanced sound with 2 inner plies of Birch for extra cut and projection. The 45 degree bearing edges provide superb sensitivity and pinpoint articulation.

## REFERENCE PURE SPECIFICATIONS

SHELLS	Low Mass Evenply Maple, Birch & African Mahogany
SNARE	6 Ply Matching 13 x 6.5, 14 x 5, 14 x 6.5"
FINISH	Super High Gloss Lacquer / Lacquer Sparkles **
HEADS	Remo Clear Emperor Tom, Powerstroke3 Bass
TOM MOUNTS	Aluminum OptiMount Suspension System
TOM ARMS	Sold Separately
HARDWARE	Chrome, Nickel, Black Chrome Plated, or Gold Plated
HOOPS	Low Mass FatTone Hoops
LUGS	Low Mass STL Swivel Tube Lugs <i>*Sold Separately</i>



RFP924XP/C  
#103 PIANO BLACK



Using the same shell composition formula as the original (number and type of wood plies, task-specific bearing edges, etc.) the highly resonant qualities of Reference Pure's lower-mass, thinner shell assure an uninhibited shell-focused tonality that responds immediately in any playing environment.

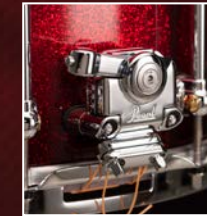

Pearl's SR1000 Glide-Lock Strainer's locking throw off lever and tension knob assures worry-free, slip-free performance from all Reference Pure Snare Drums. (US Patent #7220905, #7301087, #7365256.)

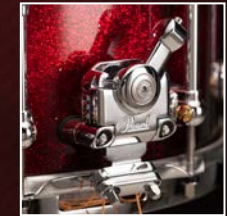

Aluminum OptiMount Suspension System mounts to the tension rods and are insulated from metal to metal contact.

Air Suspension Rubber Tip (US Patent #5881981) isolates the tom from the floor, preventing tonal choke and increasing resonance.



Pearl's Golden Ratio Air Vent (US Patent #7485791) is precision placed on toms to increase low-end response, while low-mass, low-contact STL lugs and floor tom brackets allow for increased shell sustain.



\*\* Stock finishes. See full Color Chart on back cover for all Special Order Finishes.



#102 NATURAL MAPLE #103 PIANO BLACK #377 SCARLET SPARKLE BURST

Reference Pure proudly builds upon the Masterworks philosophy started by Pearl's original Reference Series Drums.

RFP903XP/N  
#111 MATTE NATURAL w/ OPTIONAL NICKEL-PLATED HARDWARE



# MUSIC CITY CUSTOM SERIES

HAND-ASSEMBLED IN THE USA FOR TRUE PEARL ARTISTS...LIKE YOU.

ONCE EXCLUSIVELY FOR ARTISTS,  
THESE DRUMS NOW CAN BE YOURS.

INTRODUCING MUSIC CITY CUSTOM.  
THE ARTIST EXPERIENCE  
FOR EVERY DRUMMER.

For over 40 years, Pearl's exclusive USA Artist Custom shop has been collaborating with some of the most illustrious names in drumming to handcraft personal touring kits; featured on the largest live show stages across the world. Our new Music City Custom Series now allows you to experience the same level of service and pride, by owning an exclusive kit precision CNC drilled and fully assembled here at our custom shop facility within Pearl's USA corporate headquarters in Nashville, TN.



#725 SATIN GREY SEA GLASS

## MUSIC CITY CUSTOM STARTS WITH REFERENCE

Pearl is known to produce some of the finest drum shells available today, and our top of the line Masterworks and Reference shells are truly without equal. Our exclusive SST shell forming process is often copied, but never duplicated. Music City Custom drums features pristine shells of the finest wood plies, manufactured in Pearl's renowned overseas Masterworks facility, and available in your choice of either Reference or Reference Pure shell specifications. Choose from 43 drum sizes, 29 beautiful covered finishes, and either RF or RFP shell specifications to experience what our top endorsees have enjoyed for years.



\*See full Color Chart on Page 19.

#413 TURQUOISE GLASS

# MUSIC CITY CUSTOM SERIES

HAND-ASSEMBLED IN THE USA FOR TRUE PEARL ARTISTS...LIKE YOU.



## GET IT WHEN YOU NEED IT

Our goal is to complete each Music City Custom kit within 14 business days from the date we receive your order through one of our many authorized dealers. No one in the industry does this. Quick custom manufacturing, together with Pearl's exclusive lifetime warranty, massive size and color choice selections, and industry-leading craftsmanship all combine to set a new standard for what a USA born hi-end drum set should be.

## HANDCRAFTED EXCELLENCE

From hand-covering each and every shell, to precision CNC drilling, hand assembly and on to a final painstaking inspection process of every detail of each kit's manufacture, Music City Custom provides everyone the true artist experience and a drum set like no other.



#422 MATTE WHITE MARINE PEARL

## HANDCRAFTED, ARTIST DESIGNED

Explore the option of *Reference* or *Reference Pure-recipe* SST drum shells; precision drilled-to-order, assembled, and immediately available in your choice of 29 *tour-ready finishes*. From classic sparkles and vintage pearls to satin flames and current favorites, it's here and ready to define your command of the stage.



#403 RED ONYX



#405 NICOTINE WHITE MARINE PEARL (Large)



#407 RED GLASS



#409 DIAMOND GLITTER



#412 BLACK OYSTER GLITTER



#413 TURQUOISE GLASS



#414 ICE BLUE OYSTER



#415 BRONZE OYSTER



#416 BLACK N' WHITE OYSTER



#417 PEWTER ABALONE



#418 BLUE ABALONE



#419 BURNT ORANGE ABALONE



#420 GOLDEN YELLOW ABALONE



#421 BLACK DIAMOND PEARL



#423 VINTAGE GOLD SPARKLE



#424 VINTAGE BLUE SPARKLE



#425 CHARCOAL BLACK SPARKLE



#426 MIRROR CHROME



#427 BRIGHT CHAMPAGNE SPARKLE



#446 GREEN GLASS



#447 BURNT ORANGE GLASS



#448 WHITE MARINE PEARL (Large)



#720 CRANBERRY SATIN SWIRL



#721 BLUE SATIN MOIRE



#722 WHITE SATIN MOIRE



#723 GOLD SATIN MOIRE



#724 SHADOW GREY SATIN MOIRE



#725 SATIN GREY SEA GLASS

#422 MATTE WHITE MARINE PEARL PICTURED ON PAGE 18

# MASTERS MAPLE RESERVE SERIES

A CLASSIC FORMULA FOR SONIC GREATNESS.



Utilizing premium North American Maple veneers from our exclusive Masterworks supply vault, the thin, 4-ply shell configuration (with reinforcement rings) in new Masters Maple Reserve delivers a smooth, open tonality with classic resonant shimmer. All Masters drums feature Pearl's proprietary 38-step lacquering process and showcase a classic, vintage-flavored style as distinctive as the shells they adorn.

## MASTERS MAPLE RESERVE SPECIFICATIONS

SHELLS	4-ply (5mm) 100% Maple w/4-ply Maple Re-Rings
SNARE	Matching 14x5.5 or 14x6.5 (Sold Separately)
FINISH	Super High Gloss and Matte Lacquer
HEADS	Remo Clear Ambassador Tom, Ported Powerstroke3 Bass
TOM MOUNTS	Aluminum OptiMount Suspension System
DRUM HARDWARE	Chrome
HOOPS	Low Mass FatTone Hoops
LUGS	CL Bridge Lugs
BD MUFFLER	BDMF (Full Size)



Masters Maple Reserve comes standard with performance-proven 1.6mm FatTone tom hoops. Featuring an exclusive hemmed/welded edge for added stability, their low mass helps increase sustain and tonal resonance without sacrificing projection.



MRV924XEDP/C  
#359 TWILIGHT BURST

MRV923XSP/C  
#343 OLIVE BURST

## THE MASTERS LEGACY.

Featuring 4-ply Maple reinforcement rings, Masters Maple Reserve is a natural choice for the most discerning musical pallet. This classic integration increases shell stability and tonal control, delivering rich, sustained lows and lively sonic punch.



The Aluminum OptiMount suspension system provides exceptional stability and mounting control by attaching to the tom's tension rods at four corresponding points. This allows the shell to vibrate freely without restriction.



# MASTERS MAPLE COMPLETE SERIES

THE MASTERS SHELL COMES FULL CIRCLE.

Pearl's Masters Series has always been synonymous with the very best in professional instruments for the touring drummer. In creating new Masters Maple Complete drums, Pearl has crafted a refined representation of Masters' 25 year history in one total package.

**EvenPly-Six Shell:** This premium, six layer North American Maple shell incorporates reduced-thickness, cross-laminated plies. This 28% thinner shell produces the tonal purity and increased resonance of Pearl's legendary Masters MMX, while projecting with the vibrant power of the thicker MRX series.



SP30 Spurs



Insulated Die-Cast Bass Drum Claws



Sleek Bridge-Style CL Lugs

To maintain optimal resonance and articulation, Masters Maple Complete features triple-flanged SuperHoop II tom and snare hoops. Professional hardware touches include SP30 spurs, LB40 floor tom legs, insulated die-cast bass drum claws, and our sleek bridge-style CL lugs for reduced shell contact and improved shell performance.

#347 BOMBAY GOLD SPARKLE



MCT943/C  
#348 ABSINTHE SPARKLE

MCT924XEDP/C

22"x18"  
10"x7" 12"x8"

16"x16"

MCT903XP/C

20"x14"  
12"x8"

14"x14"

MCT923XSP/C

22"x16"  
12"x8"

16"x16"

MCT943XP/C

24"x14"  
13"x9"

16"x16"

## MASTERS MAPLE COMPLETE SPECIFICATIONS

SHELLS	EvenPly Six (6-ply, 5.4mm) 100% Maple
SNARE	Matching 14x5.5 or 14x6.5 (Sold Separately)
FINISH	Matte Lacquer and Lacquer Sparkles
HEADS	Remo UT Pinstripe Tom, Ported UT Powerstroke3 Bass
TOM MOUNTS	OptiMount Suspension System
DRUM HARDWARE	Chrome
HOOPS	SuperHoop II (2.3mm Triple-Flanged)
LUGS	CL Bridge Lugs
BD MUFFLER	BDMM (Mini)

## UNPARALLELED SOUND. ATTAINABLE PRICE.

The sound that made Masters a legend shines forward. With improved features and a lower price, Masters Maple Complete is the total percussive statement for the road-ready pro drummer.

Five premium lacquer finishes are available in four pre-configured shell packs, as well as a host of component and add-on drums.



#124 MATTE BLACK MIST

#346 VERMILION SPARKLE

#347 BOMBAY GOLD SPARKLE

#348 ABSINTHE SPARKLE

#351 SATIN NATURAL BURST

# SESSION STUDIO CLASSIC SERIES

THE ESSENTIAL SOUND OF STUDIO GROOVE.

Fit for virtually any style of music or venue, Session Studio Classic revives the performance-vibe of the original, with fresh, groove-inspiring tonal flavor.

WILL KENNEDY  
THE YELLOWJACKETS

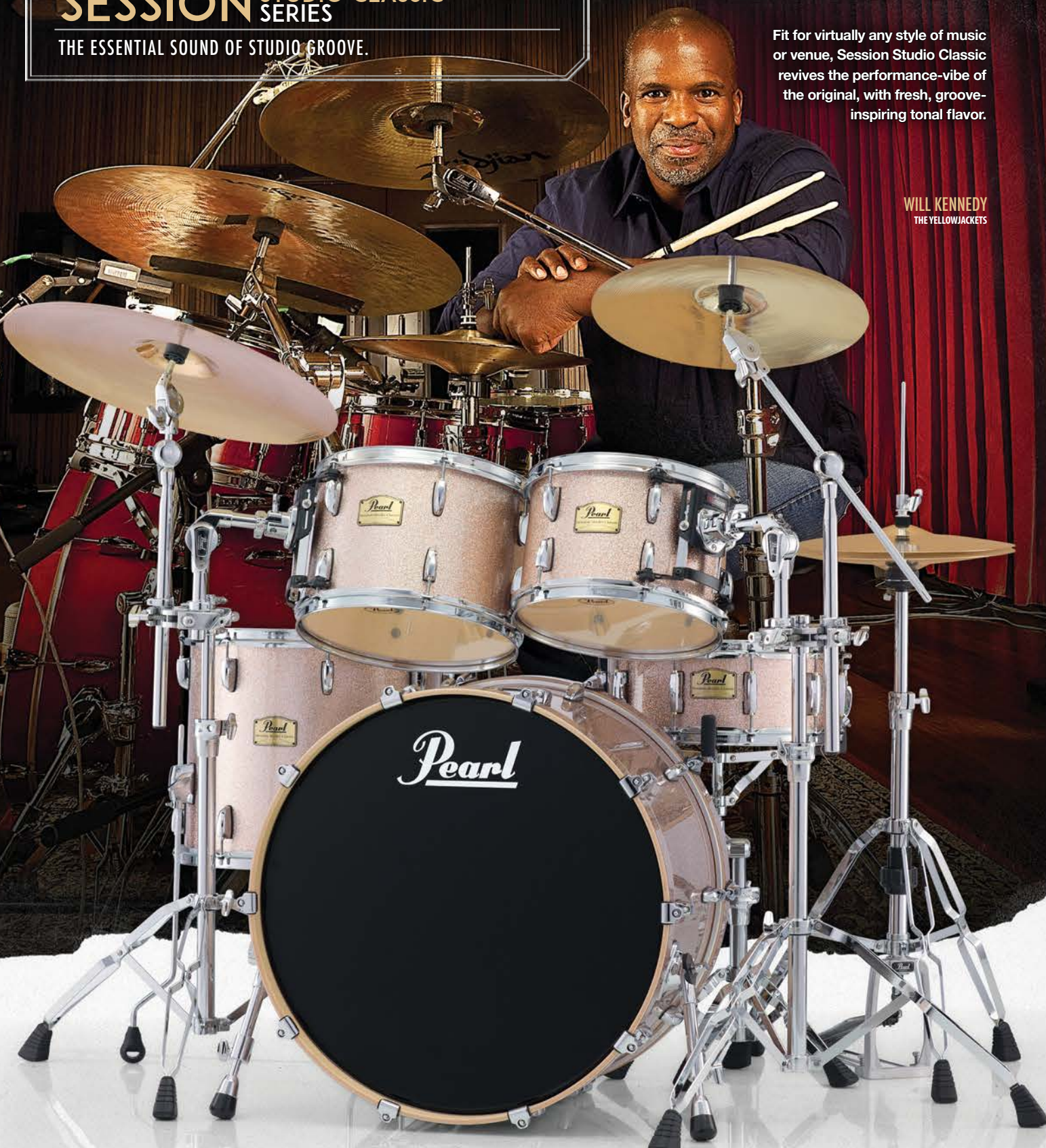

The nucleus of the Session Studio Classic sound is the blending of Kapur wood's warm, resonant qualities with the controlled brightness of Birch. Topping this timeless combination with a perfect 45° bearing edge creates a shell with powerful attack and a beautiful tonal decay.



Session toms and snare drums feature rigid yet low mass SuperHoop II Rims for ease of tuning and optimum resonance. All drums feature classic Session 'RL' Series lugs.



Pearl's OptiMount Suspension System attaches to the tom's tension rods and provides the ultimate in stability, while at the same time allowing unrestricted resonance through the shell.



SSC924XUP/C  
#110 SEQUOIA RED

TERENCE HIGGINS  
WARREN HAINES AND DFRANCO



To complement its unique shell composition, Session Studio Classic shells are crafted with traditional shallow depths. This allows energy from the stroke to flow freely through the drum, and creates a livelier tonality with vintage-flavored overtones.

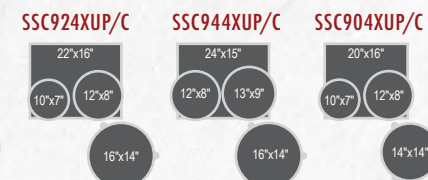

SSC924XUP/C  
#106 ANTIQUE IVORY

## SESSION SSC SPECIFICATIONS

SHELLS	6 ply Birch / Kapur 7.5mm
SNARE	Matching 14 x 5.5" or 14 x 6.5"
FINISH	Super High Gloss Lacquer
HEADS	Remo Clear Pinstripe Tom, Powerstroke3 Bass
TOM MOUNTS	OptiMount Suspension System
DRUM HARDWARE	Chrome
HOOPS	SuperHoop II 2.3mm Triple Flanged
LUGS	RL Lugs

\*Sold Separately

## CLASSIC SOUND. AMAZING VALUE.

Session Studio Classic is, without question, the ultimate value in professional drums. Offering many of the ground-breaking features normally found on drums that cost substantially more, Session Studio Classic is the perfect complement to your evolving playing style.

For a sophisticated tonal range, Session Studio Classic features a diverse selection of shell sizes to fit your style and taste, including bass drums from 20" to 24", matching snare drums, and six classic Pearl high gloss lacquer finishes.

SSC924XUP/C  
#361 VINTAGE COPPER SPARKLE



# WOOD-FIBERGLASS SERIES

VINTAGE HYBRID, MODERN PERFORMANCE.

Developed at the dawn of the 1970's, Pearl introduced Wood-Fiberglass drums as a studio solution for players looking for a louder, fatter, brighter sound. This unique synthetic-fusion shell would help put Pearl on the map, and defined the sound of an era.

Now, this classic tone returns for today's roots-conscious player. The full-bodied power of Pearl's original Wood-Fiberglass drums is back with modern craftsmanship, style, and functionality.



FW923XP/C  
#327 SATIN COCOA BURST



## THE HARDWARE

Wood-Fiberglass toms include the OptiMount suspension system to remove undue shell pressure and increase sustain. Pearl's 2.3mm triple-flanged Superhoops add to the attack without sacrificing tonal body.



## THE SHELL

True to the legacy set by Pearl's original innovative hybrid, Wood-Fiberglass drums feature a hand-applied inner layer of Fiberglass to add focus to

the darker tonal qualities of its 7-ply Poplar/Kapur wood shell. To further sculpt the tone of these unique drums, a sharp 45° edge is cut on the toms of each kit, while the bass drum features a fully-rounded edge. This and accentuates the sonic cut of Fiberglass; delivering a unique combination of warmth, projection, and focused decay.



Original shots of Wood-Fiberglass "Image Creator" kits from the 1970 Pearl Catalog.

## WOOD-FIBERGLASS SPECIFICATIONS

SHELLS	7-ply (2x Poplar / 4x Kapur / 1x Fiberglass) 7.5mm
FINISH	High Gloss and Satin Lacquer
HEADS	Remo Pinstripe Tom, Powerstroke Coated/Clear Bass
TOM MOUNTS	OptiMount Suspension System
DRUM HARDWARE	Chrome
HOOPS	Superhoop II 2.3mm Triple Flanged
LUGS	RL Lugs

## WOOD-FIBERGLASS CONFIGURATIONS

To best capture the essence of this classic sound, Wood-Fiberglass sets are available as 3-pc. shell packs in "Traditional" sizes and depths.

### FW903XP/C

20"x14"  
12"x8"

14"x14"

### FW923XP/C

22"x14"  
13"x9"

16"x16"

### FW943XP/C

24"x14"  
13"x9"

16"x16"

### FW963XP/C

26"x14"  
13"x9"

16"x16"

FW963XP/C  
#151 PLATINUM MIST

## WOOD-FIBERGLASS FINISHES

Four elite lacquer finishes have been selected from the Reference/Masterworks pallet in tribute to the originally offered wrap finishes of the 1970 offering.



#103 PIANO BLACK

#151 PLATINUM MIST

#152 ANTIQUE GOLD

#327 SATIN COCOA BURST

# CRYSTAL BEAT SERIES

THE ORIGINAL SEAMLESS ACRYLIC DRUM SET.

## CRYSTAL BEAT SPECIFICATIONS

SHELLS	7mm Seamless Molded Acrylic
SNARE	Matching Free Floater*
FINISH	Transparent
HEADS	2-Ply on Tom Batters, Single-Ply Resonant
TOM MOUNTS	OptiMount Suspension System
TOM ARMS	Sold Separately
DRUM HARDWARE	Chrome
HOOPS	1.6mm Triple-Flanged
LUGS	CB Mid-Lugs on Toms, CB Fat-Lugs on Bass

\*Sold Separately

In 1973, Pearl set a benchmark in the drumming world with the introduction of Crystal Beat. A stunning combination of visual appeal and powerful, sonic attack, Crystal Beat's revolutionary seamless construction was molded - not rolled - creating a strong acrylic drum system that could stand up to the rigors of touring.

Original Crystal Beat Kit from 1973 Pearl Catalog.



#730 ULTRA CLEAR



CRB525FP/C  
#731 RUBY RED

Not just another transparent trap kit for the hipster set, Crystal Beat's original seamless shell is back, upgraded, and fortified for today's power player.



#730 ULTRA CLEAR

#731 RUBY RED

#732 TANGERINE GLASS

#733 FROST ACRYLIC

CRB543P/C  
#732 TANGERINE GLASS

## HARDWARE

Crystal Beat's toms include the OptiMount suspension system to remove undue shell pressure and increase sustain. 1.6mm triple-flanged hoops offer just the right amount of attack without sacrificing tonal body.



CRB543P/C  
#733 FROST ACRYLIC  
18" TOM ADD-ON

## SHELL

By increasing shell thickness to 7mm, Crystal Beat's modern acrylic shell is more flexible, less brittle, and deliver more body and tone than ever before. Its dual 45° bearing edge features a rounded apex, adding control, increased articulation, and punch to acrylic's lively sonic nature.



# DECADE MAPLE SERIES

A DRUM KIT 10 YEARS IN THE MAKING.

# DECADE MAPLE

**Practice Time is Over, It's Time to Get Serious** • To elevate the playing field for today's advancing drummer, Pearl has drawn on 70 years of award-winning drum craftsmanship to create new Decade Maple series drums. The first all Maple, lacquered drum set to carry a Lifetime Warranty in this price range, Decade is built to push the boundaries of performance and value, and project your drumming voice with authority.



DMP925SP/C  
#260 SATIN BROWN BURST

DMP943XP/C  
#229 WHITE SATIN PEARL  
(Snare Sold Separately)

**The Kit You've Prepared Yourself for is Here** • With feature-heavy shell packs starting at only \$559 Street, Decade Maple drums are perfect as a primary kit for evolving players, or a secondary "gigging" kit for the seasoned pro.

## THE DECADE DIFFERENCE



Decade's 6-ply/5.4mm all Maple shell is what sets it apart from the other players in the field. The final product of ten years of process and material refinement, each cross-laminated ply incorporates Pearl's proprietary Superior Shell Technology. The resulting thin (but powerfully strong) shell reacts quickly to the stroke, producing beautifully resonant highs and thundering lows.



Pearl's three-way Opti-Loc Mounting System produces clear tone and wobble-free stability by suspending each tom at two tuning points and one of the drum's two air vents.



Decade's low-mass/low-contact shell hardware assures optimum shell performance and rock-solid durability. Features include Uni-Lock gearless tom arms, insulated die-cast claw hooks, R40 Air Suspension Floor Tom feet, and a newly-designed mini lug.



DMP927SP/C  
#261 GLOSS DEEP RED BURST



Available in five custom colors, Pearl's cultured lacquer finishing process is applied to each shell exterior to add spectacular vibrancy.



## DECADE MAPLE SPECIFICATIONS

SHELLS	6-Ply (5.4mm) 100% Maple
SNARE	14 x 5.5 Matching
FINISH	High-Gloss / Matte Lacquer
HEADS	Remo UT Clear Ambassador Tom, Ported UT Powerstroke3 Bass
TOM MOUNTS	Opti-Loc Mounting System
DRUM HARDWARE	Chrome
HOOPS	1.6mm Steel Triple Flanged
LUGS	NDL Lugs
BD MUFFLER	BDM (Mini)



# EXPORT LACQUER SERIES

THE LEGENDS OF TOMORROW, PLAY EXPORT TODAY.

Crafted to capture the look, sound, and feel of top-end gear at an accessible price, new Export Lacquer drums boast a list of features that is far beyond their low price-tag. Everything you would expect from the #1 selling drum set in the world is in the mix, upgraded, and ready to fuel the fire of drumming right out of the gate for the serious player.

## EXPORT LACQUER SPECIFICATIONS

SHELLS	Poplar and Asian Mahogany Blend
SNARE	14 x 5.5 Matching Wood Snare
FINISH	Choice of 3 High Gloss Lacquer Finishes
HEADS	Remo Clear Tom Head, Powerstroke Bass Head
TOM MOUNTS	Opti-Loc Mounting System
TOM ARMS	TH701
DRUM HARDWARE	Chrome
HARDWARE	P930, BC830, C830, H830, S830

Available in four configurations in a choice of four lacquered finishes, Export Lacquer can be expanded with a wide range of matching add-on components to create a setup as unique as your playing signature.



Pearl's Opti-Loc Mounting System's three-way attachment design utilizes rubber isolators at two tuning points and another at one of the drum's two air vents. This creates maximum sustain and resonance while providing wobble-free performance.



EXL725S/C  
#255 NIGHTSHADE LACQUER

CONFIGURATIONS  
Includes HMP930 Hardware



## THE BEST SELLING DRUM SET OF ALL TIME.

After 30 years of being the #1 Selling drum set in the world, Export Series is still the name every drummer knows. Having jumpstarted thousands of drumming careers by bringing quality and value into one package, today's Export continues to build legends.

With features like Reference-inspired shell composition, a choice of wrap (EXX) or high-gloss lacquer (EXL) finish, and our unbeatable 830-Series hardware package, Export is ready to fuel the fire for future drumming icons.



P930  
DRUM PEDAL

Export comes equipped with the P930 drum pedal. This drum pedal combines the long board design of our Demon Drive drum pedal with the interchangeable cam design of our Eliminator drum pedal for amazing performance and value.

# EXPORT SERIES

THE BEST SELLING DRUM SET OF ALL TIME.

Export's Reference-inspired blended shell combines the classic sound of Poplar with inner plies of Asian Mahogany for strong volume, deep resonance and sustained low-end frequencies.



Export Series incorporates Pearl's SST (Superior Shell Technology), Opti-Loc Mounting System, all-new 830 Series Hardware with a P930 Pedal, and a choice of six amazing stocking finishes.

## EXPORT SPECIFICATIONS

SHELLS	Poplar and Asian Mahogany Blend
SNARE	14 x 5.5 Matching Wood Snare
FINISH	Choice of 6 Covered Finishes
HEADS	Remo Clear Tom Head, Powerstroke Bass Head
TOM MOUNTS	Opti-Loc Mounting System
TOM ARMS	TH701
DRUM HARDWARE	Chrome
HARDWARE	P930, BC830, C830, H830, S830



EXX725S/C  
#708 GRINDSTONE SPARKLE

## P930 PEDAL & 830 SERIES HARDWARE



Without a doubt the most sophisticated hardware ever offered on a drum kit at this price. The BC830 Boom stand, C830 Cymbal stand, and S830 Snare Drum stand all feature infinitely adjustable Uni-Lock Tilters for pinpoint positioning. Robust 1" diameter base tubes and 7/8" diameter center tubes with sturdy double-braced tripods provide exceptional rigidity and stability. The H830 Hi-Hat stand features swivel legs that accommodate double pedals. The P930 drum pedal combines the styling and performance of the Demon Drive pedal with the Eliminator interchangeable cam technology for tried-and-true power, speed, and control.



# MIDTOWN SERIES

BIG GIG, SMALL RIG, HUGE SOUND.



Lift used on Midtown raises the drum to the optimal position for your pedal.

MDT764P/C  
#704 BLACK CHERRY GLITTER

## BIG GIG, SMALL DRUMS, HUGE SOUND.

At home on the street as well as on stage, Pearl's ultra-portable Midtown Kit is vital for the gigging drummer in the metropolitan groove.

- Full-size play in a smaller footprint.
- Elevated 16x14" kick drum delivers solid low-end foundation for solid backbeats.
- Included 10x7" tom, 13x12" floor tom, and 13x5.5" snare create a unique sonic statement.
- A full shell pack costing less than many snare drums.

## INSTANTLY PORTABLE

The Midtown Kit's compact size makes it ideal for tight spaces, and quickly breaks down into an optional two gig bag set (PMTBG, shown,) for quick transport.



## MIDTOWN SPECIFICATIONS

SHELLS	6 Ply 7.5 mm Poplar
SNARE	13 x 5.5 Matching Wood Snare
FINISH	Choice of 2 Covered Finishes
HEADS	Remo Clear Toms, Powerstroke Bass Clear Batter Coated Front
TOM ARMS	TH701
HARDWARE	Chrome

## DRUM SHELLS



6 Ply 7.5 mm Poplar



MDT764P/C  
#701 BLACK GOLD SPARKLE



#701 BLACK GOLD SPARKLE



#704 BLACK CHERRY GLITTER

## THE BEST STARTER DRUM SET AVAILABLE

True to Pearl's legacy of drum-building excellence, **ROADSHOW SERIES** is a complete drum set package including all the key elements you need to start your journey to the big time.

- **ROADSHOW's** included hardware package is second-to-none in its class
- All stands are dual-reinforced with double-braced legs
- Height and angle adjustable with locking tilters
- Double-braced Drum Throne and Cymbal package included

## THRONE INCLUDED BASS DRUM PEDAL



- Double-braced
- Height adjustable
- Comfortable for extended session



- Dual-chain drive action and adjustability
- Smooth, effortless play



RS525SC/C  
#707 BRONZE METALLIC

## CONFIGURATIONS COMPLETE SETS WITH HARDWARE & CYMBALS



RS525SC/C  
#91 RED WINE

RS525WFC/C  
#31 JET BLACK

RS505C/C  
#707 BRONZE METALLIC

RS584C/C  
#706 CHARCOAL METALLIC



## NATE MORTON THE VOICE

For additional info, testimonials, assembly videos, free instructional videos, and access to the largest online drummer's community, go to:

[WWW.MYFIRSTDRUMSET.COM](http://WWW.MYFIRSTDRUMSET.COM)



#31 JET BLACK #91 RED WINE #706 CHARCOAL METALLIC #707 BRONZE METALLIC

## DRUM SHELLS



**ROADSHOW's** bass drum, tom toms, and snare feature a 9-ply Poplar shell for optimum tonal power.

## ROADSHOW SPECIFICATIONS

SHELLS	9 Ply 7mm Asian White Poplar
SNARE	Matching Wood Snare
FINISH	Choice of 4 Covered Finishes
HEADS	Clear Tom Heads, Coated Snare Head, Self-Muffled Bass Head
TOM ARMS	Individually Locking 7/8" Tube Joint Holders
HARDWARE	Dual-Chain Drive Bass Drum Pedal Double-Braced Cymbal*, Snare, and Hi-Hat Stands Double-Braced Throne
CYMBALS	16" Brass Cymbal, 14" Brass/Hybrid Hi-Hat Cymbals
ACCESSORIES	Pro Drum Stick Bag, Two pair of Maple 5A Sticks

\*Docking Cymbal Boom Arm Included with RS 584C/C

# ePRO SERIES

THE NEW GENERATION OF REAL ELECTRONIC DRUMS.

TOMMY LEE  
MÖTLEY CRÜE



**EPEX725S/C**  
#708 GRINDSTONE SPARKLE  
WITH EP02P CYMBALS & EHH2 HI-HAT

All of these great components couldn't reach their full potential without rich drum and percussion sounds generated from the r.e.d.box drum module (r.e.d. stands for Real Electronic Drums). The 128MB RAM capacity accommodates 1000 High Definition Sounds, 150 High Definition kits, plus space for 50 user-created kits.

**r.e.d.box**  
Real • Electronic • Drums

## HIGH DEFINITION KITS - JUST A CLICK AWAY.

One very unique and exciting capability of Pearl's r.e.d.box is the Memory Switch, which gives you the ability to flash the memory and substitute a lush, super high-end drum set for the original acoustics. Pearl has partnered with professional digital drum samplers Toontrack, Zildjian, and Steven Slate Drums, to provide the lush kits through [redboxsoundshop.com](http://redboxsoundshop.com).



**RBM20MUL**  
r.e.d.box MODULE

[redboxsoundshop.com](http://redboxsoundshop.com) offers the ultimate variety of high resolution kits ready for download. Play along mp3s are available in all genres as well as historical Pearl kits.

### MEMORY SWITCH

One of the most unique features of the r.e.d.box module is the ability to flash the memory of the module and replace the Original Acoustics with one large and lush-sounding kit. Just follow these easy steps and you'll be on your way to playing premium kits on your ePro Live from the best drum sampling software companies in the world!

1. Visit [redboxsoundshop.com](http://redboxsoundshop.com) to preview and purchase specially designed kits from Zildjian, Toontrack, Steven Slate, and Pearl and download the free software that allows your PC or Mac to communicate with the r.e.d.box.
2. Connect your computer to the r.e.d.box with a USB cable.
3. Launch the Memory Switch communication software and move the Original Acoustics to your computer.
4. Using a Mac, drag and drop the Lush kit onto the r.e.d.box icon which loads in 20 minutes. (Separate instructions required for PC)
5. Reverse the process to replace the original acoustics.
6. Free samples of lush sounding kits and drumless play-a-long tracks are available at [redboxsoundshop.com](http://redboxsoundshop.com).



- Pad & Cymbal Inputs**  
12 Dual-Zone trigger inputs for 24 unique sound sources
- MIDI IN/OUT**  
Connects with external MIDI device
- USB IN/OUT**  
Input for loading new sound sets from Mac or PC. Sends and receives MIDI
- AUX IN**  
Connects to external sound source
- AUX OUT**  
Connects to monitor system or recording device (sound assignable)
- MAIN OUT**  
Connects to amplifier or speaker system (sound assignable)

**r.e.d.box 2.0 firmware updates** provide an enhanced dynamic range and sensitivity to give drummers the expression needed to appreciate the nuances of the lightest ghost notes and softest buzz rolls on stage or in the studio. Every kit has been modified to use the pitch-to-velocity function which allows samples to change in pitch when played at different velocities, creating a more realistic performance and reducing the unwanted triggering that is evident in most modules. ePro Live now supports the addition of 2 extra crash cymbals which require no additional programming when inserted to trigger inputs #10 and #11. Additional improvements have been made on the panning, EQ, and effects to provide the highest quality sonorities for recording or live performances. The fifty new kits run the gamut from Acoustic, One man Rhythm Sections and Hybrid Electronic. The r.e.d.box now has 150 kits and is the largest library available in a drum module.

## ePRO POWERED BY EXPORT

ePro Powered by Export is the new generation of electronic drums from Pearl. We have combined the power of ePro live with our new Export series to give you the real look and feel that today's drummer demands. ePro powered by export is available in both Lacquer and Wrap Finishes and includes the new EHH2 Hi Hat controller.

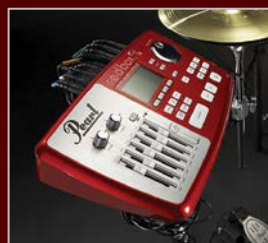

**r.e.d.box**  
Real • Electronic • Drums

The r.e.d.box module features 1000 sounds and 150 programs that covers everything from Acoustic drums to Hybrid combinations. And if that wasn't enough, you can use it as an acoustic kit, electronic kit or create a hybrid combination of both that gives you endless possibilities.

## ePRO COCKTAIL KIT A MODERN VERSION OF OLD SCHOOL DESIGN

- The first multi zone Electronic Cocktail Kit utilizing the Pearl r.e.d.box Module
- Setup with 7 programmable triggers that can be assigned with any of the 1000 sounds in the Redbox module
- The layering capability can produce endless possibilities for percussion and drum set design
- Can be used by drummers and percussionists who want to have the real look and feel on stage



**EPCTK1424/SC**  
#400 WHITE MARINE PEARL

**EPCTK1424/SC**  
#402 ABALONE

# PRO SERIES

AS SIMPLE AS CHANGING A DRUM HEAD.

## TRUTRAC PACK + CYMBALS

Pearl's TruTrac Electronic Drumheads are available in pre-packs and individual components so you can convert your own acoustic kit into an electronic kit. Both pre-packs include (5) No Drill Adapters and all necessary parts and tools to complete your kit's conversion from acoustic to electronic. Connect the pads to your favorite module, Hi-Hat controller and cymbals to enhance your current electronic kit, and you're good to go!



TruTrac Pack Conversion Kits are available in two configurations: 10/12/16/14/Bass and 12/13/16/14/Bass.



No-Drill adapters connect through your air vent with no soldering or drilling required.



Insert the longer supplied tension rods into your existing hoops and tighten them just enough to secure the TruTrac Electronic Drumhead.

SSC924XUP/C  
#389 MATTE LIQUID AMBER  
WITH EPADRB25S CONVERSION KIT



## TRUTRAC HI-HAT



EHH2  
TRUTRAC HI-HAT



The TruTrac hi-hat is designed to replicate the look and feel of its acoustic counterpart. It follows a traditional approach mounting on any acoustic hi-hat stand. The TruTrac Hi-Hat uses top and bottom cymbals with full motion for a natural playing experience. When combined with the r.e.d.box sound module, it produces sounds from open to closed, half-open and three quarter positions plus "chik" and splash. Pearl designed the TruTrac Hi-Hat to be the perfect upgrade for ePro Live and the TruTrac Pad conversion kits.

## drumlite™

DRUMLITE  
PUTTING THE SPOTLIGHT BACK ON THE DRUMMER!

- The Drumlite banded LED illumination system is a quick, easy way to customize any drum set, and bring stage focus back where it belongs: on YOU!
- Each shock-mounted, fitted LED strip installs quickly on any drum with no soldering, drilling, or modification to the shell.
- Light bands interlock with tour-ready XLR connectors for flexible expansion and positioning
- Illuminates drum shell interior with up to 16 different colors
- Choose from four Flashing or Fading programmed presets
- On one or multiple drums in your set-up, Drumlite lets you create a unique statement that will outshine the rest!



### DUAL-BAND LED DRUMSET LIGHTING SYSTEMS

- DLK1D Dual LED Lighting Kit for 12x9, 14x14, 16x16, 22x18
- DLK2D Dual LED Lighting Kit for 10x8, 12x9, 16x16, 22x18
- CONTENTS: Dual Flexible RGB LED Strip Lights for Each Drum, Connector Mounts, LED Controller with Wireless Remote, Multi-Position XLR Cable Snake, A/C Adapter

### SINGLE-BAND LED DRUMSET LIGHTING SYSTEMS

- DLK1S Single LED Lighting Kit for 12x9, 14x14, 16x16, 22x18
- DLK2S Single LED Lighting Kit for 10x8, 12x9, 16x16, 22x18
- CONTENTS: Single Flexible RGB LED Strip Lights for Each Drum, Connector Mounts, LED Controller with Wireless Remote, Multi-Position XLR Cable Snake, A/C Adapter

### BASS DRUM LED DRUMSET LIGHTING SYSTEMS

- DLK20 Single LED Lighting Kit for 20" bass drum
- DLK22 Single LED Lighting Kit for 22" bass drum
- DLK24 Single LED Lighting Kit for 24" bass drum
- CONTENTS: Single Flexible RGB LED Strip Light, Connector Mount, LED Controller with Wireless Remote, 10' XLR Cable, A/C Adapter



## tune-bot

### TUNE-BOT

Every guitar player has an electronic tuner for speed and accuracy in tuning. Tuning a drum is much more time consuming and difficult... until now. Overtone Labs created a fast, accurate and effective electronic drum tuner that will change the way you tune and sound.

- Measures True Fundamental and Lug-To-Lug Pitch
- Interval Tuning of Toms
- Displays Pitch in Hertz and Musical Notes
- Saves Tunings for Over 20 Drums
- Conveniently Clips to Drum Hoop



TB001

## tune-bot<sup>gig</sup>

### TUNE-BOT GIG

The Gig features a large LCD display and is optimized for ease of use in the studio, on stage or in your practice room at home. The redesigned clip easily attaches to any standard drum hoop and the new silver body is easier to spot in your gig bag.

- New Streamlined Design
- Lug Pitch Measurement
- Overall Pitch Measurement
- Frequency and Note Modes
- Overtone Filters
- Difference Mode



TBG001

### DRUM MONITORS

Pearl's Precision Drum Monitors are a closed dynamic headphone of exceptional quality suitable for the most demanding professional applications. Based on the highly acclaimed Beyer Dynamic DT770 Pro, Pearl's PDM250 has been custom engineered as the ultimate drum monitoring headphone for recording studios, post production, or broadcasting situations.



PDM250

### THRONE THUMPER

Compatible with any electronic drum set and attachable to any throne. The Throne Thumper is equally at home vibrating your kit's low frequencies to you as you practice, or letting you feel the bass player's groove in a live show environment where hearing the other musicians is tough. Installation is easy and coupled with Pearl's Precision Drum Monitors, you'll hear every sonic nuance that your kit produces.



THMP1

### DRUMOMETER



DR2000

The Drumometer Model II measures a drummer's technical accuracy, hand or foot speed, and endurance by counting the total number of strokes a drummer can play within a preset time (1 to 900 seconds). It's a very progressive practice tool to help develop a relaxed playing style, strengthen endurance, and improve your sense of timing. The Drumometer is an effective teaching device for any drum instructor as students have a tangible goal to surpass.

Technical accuracy can only be measured by creating consistent and relaxed strokes and the Drumometer will show you exactly how well a pattern is being executed.



**ADRIAN BENT**  
DRAKE



**AREJAY HALE**  
HALESTORM



**ARIËN VAN WEENSENBEEK**  
EPICA



**BAARD KOLSTAD**  
LEPROUS



**BARRY KERCH**  
SHINEDOWN

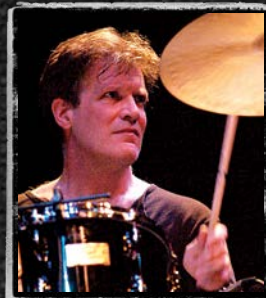

**GARY HUSBAND**  
INDEPENDENT



**GENE HOGLAN**  
TESTAMENT / DETHKLOK

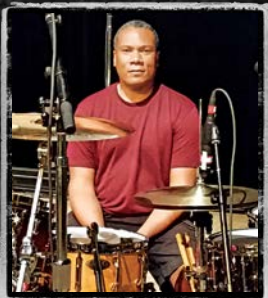

**GENE LAKE**  
BOZ SCAGGS



**GEORGE KOLLIAS**  
NILE



**GRANT COLLINS**  
INDEPENDENT



**BEN JOHNSTON**  
BIFFY CLYRO



**BRIAN FRASIER-MOORE**  
MADONNA

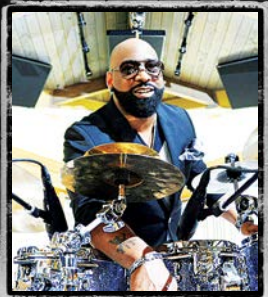

**CALVIN RODGERS**  
FRED HAMMOND



**CASEY COOPER**  
COOP3RDRUMM3R



**BRIAN VODINH**  
10 YEARS



**HORACIO HERNANDEZ**  
LATIN LEGEND



**IAN PAICE**  
DEEP PURPLE



**IGOR CAVALERA**  
CAVALERA CONSPIRACY



**INFERNO**  
BEHEMOTH



**JAMIE PERKINS**  
THE PRETTY RECKLESS



**CASEY GRILLO**  
KAMELOT

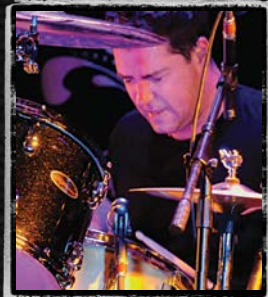

**CHAD GRACEY**  
LIVE



**CHAD SEXTON**  
311



**CHAD SMITH**  
RED HOT CHILI PEPPERS



**CHRIS RALLES**  
PAT BENATAR



**JASKA**  
CHILDREN OF BODOM



**JASON BITTNER**  
SHADOWS FALL/FLOTSAM & JETSAM



**JASON HARTLESS**  
INDEPENDENT



**JEN LEDGER**  
SKILLET



**JEREMY SPENCER**  
FIVE FINGER DEATH PUNCH



**CODY DICKINSON**  
NORTH MISSISSIPPI ALLSTARS



**CODY HANSON**  
HINDER



**DANI LOBLE**  
HELLOWEEN



**DANIEL ERLANDSSON**  
ARCH ENEMY



**DAVID AGOLIA**  
REV THEORY



**JEREMY STRATTON**  
HED P.E.



**JESSIE CARABALLO**  
MARC ANTHONY



**JIMMY HILL**  
FANTASIA



**JOE TOMINO**  
MATISYAHU/DUB TRIO



**JOEY BACA**  
THE CONTORTIONIST



**DAVID BLACK**  
EASTON CORBIN



**DENNIS CHAMBERS**  
DRUMMING LEGEND



**EMAN CERVANTES**  
ANDY GRAMMER



**ERIC SINGER**  
KISS



**FLO MOUNIER**  
CRYPTOPSY



**JOEY JORDISON**  
INDEPENDENT



**JOEY KRAMER**  
AEROSMITH



**JOHN LONGSTRETH**  
ORIGIN



**JON LARSEN**  
VOLBEAT



**JONATHAN MOYER**  
INDEPENDENT



**JOSH "CHACHI" MARUNDE**  
POP EVIL



**KAI HAHTO**  
NIGHTWISH



**KENWOOD DENNARD**  
INDEPENDENT



**KRIS MYERS**  
UMPHREY'S MCGEE



**MARK ALFRED**  
RIVERDANCE



**ROBBY AMEEN**  
INDEPENDENT



**ROBERT ORTIZ**  
ESCAPE THE FATE



**RODNEY HOWARD**  
AVRIL LAVIGNE



**RYAN MORAN**  
SLIGHTLY STOOPID



**RYAN VAN POEDEROOYEN**  
DEVIN TOWNSEND PROJECT



**MARK BRZEZICKI**  
BIG COUNTRY



**MARVIN "SMITTY" SMITH**  
INDEPENDENT



**MATT ABTS**  
GOVT MULE



**MELVIN BALDWIN**  
JUSTIN BIEBER/NEW EDITION



**MICHAEL CARTELLONE**  
LYNYRD SKYNYRD



**SAM LOEFFLER**  
CHEVELLE



**SCOTT ROCKENFIELD**  
QUEENSRYCHE

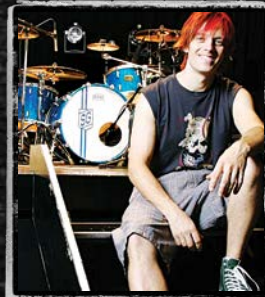

**SHANE GAALAAS**  
B'Z/COSMOSQUAD



**SHAUN FOIST**  
BREAKING BENJAMIN



**STEVEN PULLEY**  
SAVING ABEL



**MIKE COOLEN**  
WITHIN TEMPTATION



**MIKE MANGINI**  
DREAM THEATER



**MIKE REID**  
RIHANNA/DEMI LOVATO



**MIKE WENGTEN**  
DISTURBED



**MIKKO SIREN**  
APOCALYPTICA

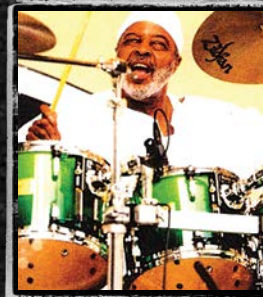

**STIX HOOPER**  
THE CRUSADERS



**TERENCE HIGGINS**  
WARREN HAYNES/ANI DIFRANCO



**TODD SUCHERMAN**  
STYX



**TOMMY LEE**  
MÖTLEY CRÜE



**TOMMY PORTIMO**  
SONATA ARCTICA

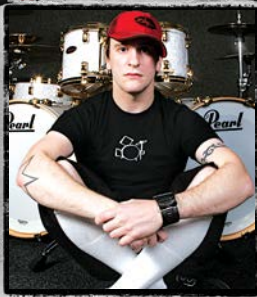

**MOOSE**  
BULLET FOR MY VALENTINE



**MORGAN ROSE**  
SEVENDUST

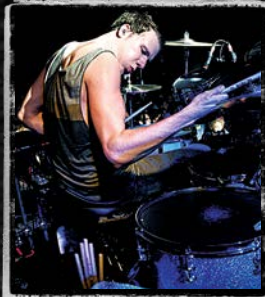

**MORITZ MUELLER**  
THE INTERSPHERE



**NATE MORTON**  
THE VOICE



**OMAR HAKIM**  
INDEPENDENT



**TONY PALERMO**  
PAPA ROACH



**TRACY BROUSSARD**  
BLAKE SHELTON



**TRAVIS ORBIN**  
DARKEST HOUR



**TRE STAFFORD**  
ADELITAS WAY



**VITO REZZA**  
INDEPENDENT



**PAUL KOEHLER**  
SILVERSTEIN

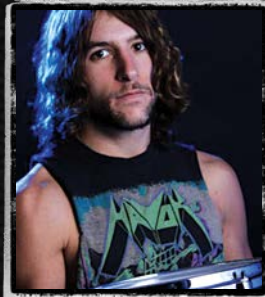

**PETE WEBBER**  
HAVOK

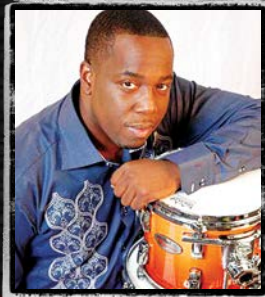

**QUINTON ROBINSON**  
INDEPENDENT



**RANDY BLACK**  
DUSKMACHINE

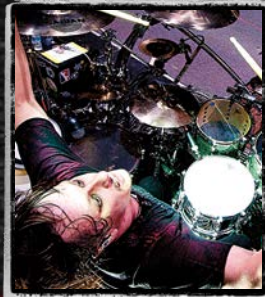

**RAY LUZIER**  
KORN/KXM



**WES LITTLE**  
ROBBEN FORD



**WILL HUNT**  
EVANESCENCE

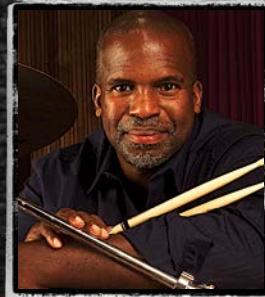

**WILL KENNEDY**  
YELLOWJACKETS



**WUV**  
P.O.D.



**YONRICO SCOTT**  
DEREK TRUCKS BAND

# REFERENCE SNARE DRUMS

THE ULTIMATE STABLE OF SNARES.

# SERIES COMPONENT SNARE DRUMS

MASTERS, SESSION, DECADE, & SENSITONE SNARES. CLASSIC PEARL SOUND.



<b>RFP1465S/C</b>	SIZE 14" x 6.5"
SHELL	6 ply: Maple 4 + Birch 2
HOOPS	FatTone (FH1410/1410S)
LUGS	STL65
TENSION RODS	SST5047 Stainless Steel
STRAINER	SR1000 Glide-Lock Strainer
SNARES	SN1420D Ultra-Sound "D" type



<b>RFP1450S/C</b>	SIZE 14" x 5"
SHELL	6 ply: Maple 4 + Birch 2
HOOPS	FatTone Hoops (FH1410/1410S)
LUGS	STL55L
TENSION RODS	SST5047 Stainless Steel
STRAINER	SR1000 Glide-Lock Strainer
SNARES	SN1420D Ultra-Sound "D" type



<b>RFP1365S/C</b>	SIZE 13" x 6.5"
SHELL	6 ply: Maple 4 + Birch 2
HOOPS	FatTone Hoops (FH1308/1308S)
LUGS	STL65
TENSION RODS	SST5047 Stainless Steel
STRAINER	SR1000 Glide-Lock Strainer
SNARES	SN1320D Ultra-Sound "D" type



<b>RF1465S/B</b>	SIZE 14" x 6.5"
SHELL	20 ply: Maple 14 + Birch 6
HOOPS	MasterCast (DC1410/1410S)
LUGS	BRL65
TENSION RODS	SST5047 Stainless Steel
STRAINER	SR1000 Glide-Lock Strainer
SNARES	SN1420D Ultra Sound "D" type



<b>RF1450S/C</b>	SIZE 14" x 5"
SHELL	20 ply: Maple 14 + Birch 6
HOOPS	MasterCast (DC1410/1410S)
LUGS	BRL55
TENSION RODS	SST5047 Stainless Steel
STRAINER	SR1000 Glide-Lock Strainer
SNARES	SN1420D Ultra Sound "D" type



<b>RF1365S/C</b>	SIZE 13" x 6.5"
SHELL	20 ply: Maple 14 + Birch 6
HOOPS	MasterCast (DC1308/1308S)
LUGS	BRL (8)
TENSION RODS	SST5047 Stainless Steel
STRAINER	SR1000 Glide-Lock Strainer
SNARES	SN1320D Ultra Sound "D" type



<b>MRV1455S</b>	SIZE 14" x 5.5"
SHELL	4 Ply Maple w/4 ply Maple R-Rings
HOOPS	FatTone (FH1410/1410S)
LUGS	STL65
TENSION RODS	SST5047 Stainless Steel
STRAINER	SR017
SNARES	S022N



<b>MCT1455S</b>	SIZE 14" x 5.5"
SHELL	6 Ply Maple (5.4mm)
HOOPS	SuperHoop II (SH1410B/1410S)
LUGS	CL55
TENSION RODS	T062
STRAINER	SR017
SNARES	S022N



<b>SSC1455S/C</b>	SIZE 14" x 5"
SHELL	6 ply 7.5mm Birch/Kapur
HOOPS	SuperHoop II (SH1410B/1410S)
LUGS	CL55
TENSION RODS	T062
STRAINER	SR017
SNARES	S022N



<b>MRV1465S</b>	SIZE 14" x 6.5"
SHELL	4 Ply Maple w/4 ply Maple R-Rings
HOOPS	FatTone (FH1410/1410S)
LUGS	STL55
TENSION RODS	SST5055 Stainless Steel
STRAINER	SR017
SNARES	S022N



<b>MCT1465S</b>	SIZE 14" x 6.5"
SHELL	6 Ply Maple (5.4mm)
HOOPS	SuperHoop II (SH1410B/1410S)
LUGS	CL65
TENSION RODS	T062
STRAINER	SR017
SNARES	S022N



<b>SSC1465S/C</b>	SIZE 14" x 6.5"
SHELL	6 ply 7.5mm Birch/Kapur
HOOPS	SuperHoop II (SH1410B/1410S)
LUGS	CL65
TENSION RODS	T061L
STRAINER	SR017
SNARES	S022N



<b>RFB1465</b>	SIZE 14" x 6.5"
SHELL	3mm Brass
HOOPS	MasterCast (DC1410/1410S)
LUGS	BRL65
TENSION RODS	SST5047 Stainless Steel
STRAINER	SR1000 Glide-Lock Strainer
SNARES	SN1420D Ultra-Sound "D" type



<b>RFB1450</b>	SIZE 14" x 5"
SHELL	3mm Brass
HOOPS	MasterCast (DC1410/1410S)
LUGS	BRL55
TENSION RODS	SST5047 Stainless Steel
STRAINER	SR1000 Glide-Lock Strainer
SNARES	SN1420D Ultra-Sound "D" type



<b>RFS1465</b>	SIZE 14" x 6.5"
SHELL	2.5mm Cast Steel / 2.5mm R-Ring
HOOPS	MasterCast (DC1410/1410S)
LUGS	BRL65
TENSION RODS	SST5047 Stainless Steel
STRAINER	SR1000 Glide-Lock Strainer
SNARES	SN1420D Ultra-Sound "D" type



<b>RFS1450</b>	SIZE 14" x 5"
SHELL	2.5mm Cast Steel / 2.5mm R-Ring
HOOPS	MasterCast (DC1410/1410S)
LUGS	BRL55
TENSION RODS	SST5047 Stainless Steel
STRAINER	SR1000 Glide-Lock Strainer
SNARES	SN1420D Ultra-Sound "D" type



<b>DMP1455S</b>	SIZE 14" x 5.5"
SHELL	6 Ply Maple (5mm)
HOOPS	1.6mm Steel (RH1408/1408S)
LUGS	NDL55/C
TENSION RODS	SST5047
STRAINER	SR700
SNARES	SNW1420



<b>SST1455S/C</b>	SIZE 14" x 5.5"
SHELL	1mm Steel
HOOPS	1.6mm Steel (RH1408/1408S)
LUGS	TLS55
TENSION RODS	TR5052
STRAINER	SR900
SNARES	SNW1420

# FREE FLOATING SNARE DRUMS

THE ULTIMATE PURITY OF SOUND.



**SEE AND HEAR**  
ALL 8 FREE FLOATING SNARE DRUMS  
pearldrums.com/2minute

**Task-Specific Innovation** Just as each player has an individual voice, snare drums speak differently depending on shell type, size, weight, and application. With the latest Free Floating snare models, Pearl's engineers crafted each to fit a specific task by model. By combining the tonal character of each shell type with its ideally-matched depth - and adding different Ultra-Sound snare wires to further sculpt individual tonal personality - these Task-Specific Free Floating snares give the player a unique voice for any sonic situation.

**Click-Lock Throw-Off System** Featured on all new Free Floating snare models, the Click Lock Throw-Off is engineered with Polymer bearings for precise and smooth action. The unique nylon grip mechanism locks the snares into place at the top position, and disengages quickly when released. (U.S. Patent #9082376)



30 years ago, Pearl introduced the Free Floating Snare Drum. A milestone achievement in snare drum evolution, this unique system removes all hardware from the shell to greatly improve the drum's resonance and projection.

Free Floating snare models are tailored to bring power, clarity, and true articulation to fit nearly any playing environment; and advance the instrument even further for a new breed of players.



• Deep, rich snare power with short, even sustain decay.

<b>FTAL1480</b>	<b>SIZE 14" x 8"</b>
SHELL	1.2mm Seamless Aluminum
HOOPS	MasterCast (DC1410/DC1410S)
LUGS	FT80
TENSION RODS	SST5042
STRAINER	SR160F
SNARES	SN1442C



• Ultimate in throaty, deep snare growl. Shortened decay.

<b>FTMH1480</b>	<b>SIZE 14" x 8"</b>
SHELL	8 ply (10mm) African Mahogany
HOOPS	MasterCast (DC1410/DC1410S)
LUGS	FT80
TENSION RODS	SST5042
STRAINER	SR160F
SNARES	SN1442C



• Lower overtone body, preserves crisp top-end snare snap.

<b>FTPB1465</b>	<b>SIZE 14" x 6.5"</b>
SHELL	1.2mm Phosphor Bronze
HOOPS	MasterCast (DC1410/DC1410S)
LUGS	FT65
TENSION RODS	SST5042
STRAINER	SR160F
SNARES	SN1420C



• Full-spectrum, both bright in punch and warm in tone.

<b>FTBR1450</b>	<b>SIZE 14" x 5"</b>
SHELL	1mm Brass
HOOPS	MasterCast (DC1410/DC1410S)
LUGS	FT50
TENSION RODS	SST5042
STRAINER	SR160F
SNARES	SN1420I



• 1mm shell for bright, open attack with ringy overtone.

<b>FTSS1435</b>	<b>SIZE 14" x 3.5"</b>
SHELL	1mm Stainless Steel
HOOPS	MasterCast (DC1410/DC1410S)
LUGS	FT35
TENSION RODS	SST5035
STRAINER	SR160F
SNARES	SN1420D



• Full, rounded bottom frequencies. Extra midrange body.

<b>FTMMH1465</b>	<b>SIZE 14" x 6.5"</b>
SHELL	6 ply (7.5mm)*
HOOPS	MasterCast (DC1410/DC1410S)
LUGS	FT65
TENSION RODS	SST5042
STRAINER	SR160F
SNARES	SN1420C



• Punchy and smooth. A perfect "go-to" snare.

<b>FTMM1450</b>	<b>SIZE 14" x 5"</b>
SHELL	6 ply (7.5mm) Maple
HOOPS	MasterCast (DC1410/DC1410S)
LUGS	FT50
TENSION RODS	SST5042
STRAINER	SR160F
SNARES	SN1420I



• Dense all Birch shell delivers bright, open attack.

<b>FTBB1435</b>	<b>SIZE 14" x 3.5"</b>
SHELL	6 ply (5.4mm) Birch
HOOPS	MasterCast (DC1410/DC1410S)
LUGS	FT35
TENSION RODS	SST5035
STRAINER	SR160F
SNARES	SN1420D

\*4 ply Maple w/2 ply inner African Mahogany



**SEE AND HEAR**  
ALL 7 HYBRID EXOTIC SNARE DRUMS  
pearldrums.com/2minute

# HYBRID EXOTIC SNARE DRUMS

SPACE-AGE PRECISION, TIMELESS TONE.



To capture sonic perfection for true professional, Pearl's latest experiments with different material combinations have yielded new tonal frontiers in our new Hybrid Exotic Series snare drums. The purest representation of Pearl's finest craftsmanship, Hybrid Exotic shell choices include spun-composite VectorCast™, dual-step seamless Cast Aluminum, and cross-laminated Kapur and Fiberglass, for the ultimate in power and prestige.



**Introducing VectorCast™** A single tiny strand can make all the difference in the world. Beginning with a composite material filament and resin thread, Pearl's new VectorCast shell is formed around a mandrel in an X-pattern; creating a thin, high-strength shell that "flexes" with each strike. Its characteristic sound is both lively and fat, and is a vast departure from other synthetics like Acrylic or Carbon Fiber.



**Glide-Lock Throw-Off System** Pearl's SR1000 Glide-Lock Strainer's locking throw-off lever and tension knob assures worry free, slip-free performance from all Hybrid Exotic Snare Drums. (US Patent #7220905, #7301087, #7365256.)



**NEW Spin-Tight™ Tension Rods** To maintain tuning tension across the batter head, all Hybrid Exotic snare drums feature Pearl's new Spin-Tight tension rods. This elegantly simple innovation creates a tension rod-within-a-tension rod, that allows the rod to expand and lock into place within the swivel nut. Utilizing a special drum key, tunings can be controlled under high-impact play like never before. (Patent Pending)



• Quick, yielding snap with heavy midrange overtones.

<b>HEP1450</b>	<b>SIZE 14" x 5"</b>
SHELL	VectorCast
HOOPS	SuperHoop II (SH1410B/1410S)
LUGS	STL100
TENSION RODS	SPT5047 (top) – SST5047 (bottom)
STRAINER	SR1000
SNARES	SN1420C



• Full-Spectrum snare body with thick bottom-end tonality.

<b>HEP1465</b>	<b>SIZE 14" x 6.5"</b>
SHELL	VectorCast
HOOPS	SuperHoop II (SH1410B/1410S)
LUGS	STL100
TENSION RODS	SPT5047 (top) – SST5047 (bottom)
STRAINER	SR1000
SNARES	SN1420C



• Dry, high-pitched crack with little overtone.

<b>HEAL1450</b>	<b>SIZE 14" x 5"</b>
SHELL	Cast Aluminum: 3mm w/ 2mm R-Rings
HOOPS	SuperHoop II (SH1410B/1410S)
LUGS	STL100
TENSION RODS	SPT5047 (top) – SST5047 (bottom)
STRAINER	SR1000
SNARES	SN1420I



• Fat midrange focus without sacrificing volume.

<b>HEAL1465</b>	<b>SIZE 14" x 6.5"</b>
SHELL	Cast Aluminum: 3mm w/ 2mm R-Rings
HOOPS	SuperHoop II (SH1410B/1410S)
LUGS	STL100
TENSION RODS	SPT5047 (top) – SST5047 (bottom)
STRAINER	SR1000
SNARES	SN1420I



• Articulate snare punch, best at higher tunings.

<b>HEK1450</b>	<b>SIZE 14" x 5"</b>
SHELL	6 ply 7.5mm Kapur w/Inner Fiberglass
HOOPS	SuperHoop II (SH1410B/1410S)
LUGS	STL100
TENSION RODS	SPT5047 (top) – SST5047 (bottom)
STRAINER	SR1000
SNARES	SN1420D



• A lively blend of throaty snare holler and punchy projection.

<b>HEK1465</b>	<b>SIZE 14" x 6.5"</b>
SHELL	6 ply 7.5mm Kapur w/Inner Fiberglass
HOOPS	SuperHoop II (SH1410B/1410S)
LUGS	STL100
TENSION RODS	SPT5047 (top) – SST5047 (bottom)
STRAINER	SR1000
SNARES	SN1420D



• Low, thunderous wallop with deep, solid playability.

<b>HEK1480</b>	<b>SIZE 14" x 8"</b>
SHELL	6 ply 7.5mm Kapur w/Inner Fiberglass
HOOPS	SuperHoop II (SH1410B/1410S)
LUGS	STL100
TENSION RODS	SPT5047 (top) – SST5047 (bottom)
STRAINER	SR1000
SNARES	SN1442D



# SENSITONE SNARE DRUMS

CLASSIC, RELIABLE SNARE POWER.

The Sensi Tone sound is a necessity. Vital, immediate snare tone that has recalls the chart-topping legends of yesterday, but with a undeniably modern sensibility. Classic beaded shells in Steel, Nickel-Plated Brass, and Seamless Aluminum deliver the goods and the right gig-ready touches make them utility standards for the power player.



**SEE AND HEAR**  
ALL 6 SENSITONE SNARE DRUMS  
[pearldrums.com/2minute](http://pearldrums.com/2minute)



**SEE AND HEAR**  
ALL 7 SENSITONE PREMIUM DRUMS  
[pearldrums.com/2minute](http://pearldrums.com/2minute)



• Crisp, sensitive high-pitched snap.

<b>STA1450S</b>	<b>SIZE 14" x 5"</b>
SHELL	1mm Beaded Steel
HOOPS	SuperHoop II (SH1410B/1410S)
LUGS	TB55
TENSION RODS	SST5047
STRAINER	SR150
SNARES	SN1420I



• Perfect blend of attack and brassy body.

<b>STA1450BR</b>	<b>SIZE 14" x 5"</b>
SHELL	1mm Beaded Brass
HOOPS	SuperHoop II (SH1410B/1410S)
LUGS	TB55
TENSION RODS	SST5047
STRAINER	SR150
SNARES	SN1420I



• Dry, focused crack with quick decay.

<b>STA1450AL</b>	<b>SIZE 14" x 5"</b>
SHELL	1.2mm Beaded Seamless Aluminum
HOOPS	SuperHoop II (SH1410B/1410S)
LUGS	TB55
TENSION RODS	SST5047
STRAINER	SR150
SNARES	SN1420I



• Belting crack with mild midrange overtone.

<b>STA1465S</b>	<b>SIZE 14" x 6.5"</b>
SHELL	1mm Beaded Steel
HOOPS	SuperHoop II (SH1410B/1410S)
LUGS	TB65
TENSION RODS	SST5047
STRAINER	SR150
SNARES	SN1420I



• An elegant solution for punch and warmth.

<b>STA1465BR</b>	<b>SIZE 14" x 6.5"</b>
SHELL	1mm Beaded Brass
HOOPS	SuperHoop II (SH1410B/1410S)
LUGS	TB65
TENSION RODS	SST5047
STRAINER	SR150
SNARES	SN1420I



• Full, guttural snare bellow with little overtone.

<b>STA1465AL</b>	<b>SIZE 14" x 6.5"</b>
SHELL	1.2mm Beaded Seamless Aluminum
HOOPS	SuperHoop II (SH1410B/1410S)
LUGS	TB65
TENSION RODS	SST5047
STRAINER	SR150
SNARES	SN1420I

**Throw-Off System: SR150 Strainer**  
The secret behind Pearl's new patent pending Click-Lock Strainer System is a "C"-shape clip that clicks onto the tension dial. This prevents the lever from disengaging, and the tension dial from loosening, even if the tension is very low. A Polymer bearing on the axle provides smooth and accurate action, and reliably quick response from the lever. (U.S. Patent #9082376)

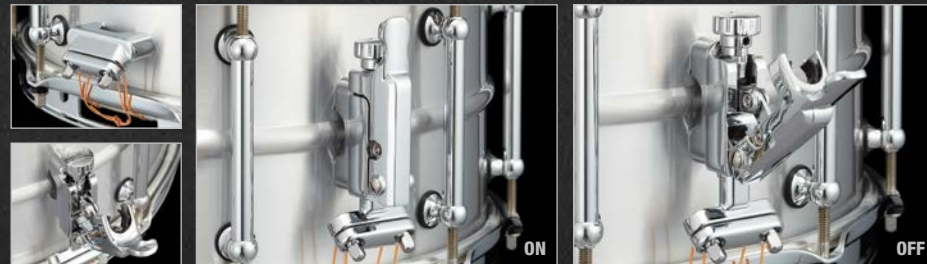

# SENSITONE PREMIUM SNARE DRUMS

IMMACULATE PERCUSSION.



• Bright and responsive with lively overtone.

<b>STA1450FB</b>	<b>SIZE 14" x 5"</b>
SHELL	1.5mm Beaded Brass
HOOPS	SuperHoop II (SH1410B/1410S)
LUGS	ARL55
TENSION RODS	SST5047
STRAINER	SR150
SNARES	SN1420I



• Bold projection with controlled ring sustain.

<b>STA1465FB</b>	<b>SIZE 14" x 6.5"</b>
SHELL	1.5mm Beaded Brass
HOOPS	SuperHoop II (SH1410B/1410S)
LUGS	ARL65
TENSION RODS	SST5047
STRAINER	SR150
SNARES	SN1420I



• Musical and penetrating with mid-range power.

<b>STA1450PB</b>	<b>SIZE 14" x 5"</b>
SHELL	1.2mm Phosphor Bronze
HOOPS	SuperHoop II (SH1410B/1410S)
LUGS	ARL55
TENSION RODS	SST5047
STRAINER	SR150
SNARES	SN1420I



• Bellowing low-end whallop with smooth articulation.

<b>STA1465PB</b>	<b>SIZE 14" x 6.5"</b>
SHELL	1.2mm Phosphor Bronze
HOOPS	SuperHoop II (SH1410B/1410S)
LUGS	ARL65
TENSION RODS	SST5047
STRAINER	SR150
SNARES	SN1420I

## Sensi Tone Premium

Engineered for performance perfection, Sensi Tone Premium snare drums feature a choice of Patina Beaded Brass, Beaded Phosphor Bronze, or even-ply North American Maple shells. With 14" models available in 5" and 6.5" depths, the Premium line's newcomer is the new African Mahogany 15"x5" Baritone snare model, adding an additional voice to the tonal pallet.

Sensi Tone Premium's selection of refined percussion instruments truly demand a place of prestige, and are sure to be first-call drums for the stage, studio, and beyond.



Pearl's stylish new Arch-Tube Lugs come standard on all Sensi Tone Premium snares. The low-contact Arch casting includes two self-aligning swivel nuts rather than a contiguous tube. This allows for pristine tuning across the head and reduced margin for binding within the lug. (Patent Pending)



• Top-end projection with fat highs and mids.

<b>STA1450MM</b>	<b>SIZE 14" x 5"</b>
SHELL	6 ply 5.4mm Maple
HOOPS	SuperHoop II (SH1410B/1410S)
LUGS	ARL55
TENSION RODS	SST5047
STRAINER	SR150
SNARES	SN1420D



• Thick snare tone with suppressed mid-tonality.

<b>STA1465MM</b>	<b>SIZE 14" x 6.5"</b>
SHELL	6 ply 5.4mm Maple
HOOPS	SuperHoop II (SH1410B/1410S)
LUGS	ARL65
TENSION RODS	SST5047
STRAINER	SR150
SNARES	SN1420D



• The Baritone Snare; low-end tone with top-end snap.

<b>STA1550MH</b>	<b>SIZE 15" x 5"</b>
SHELL	4 ply 5mm African Mahogany*
HOOPS	SuperHoop II (SH1510B/1510S)
LUGS	ARL55
TENSION RODS	SST5047
STRAINER	SR150
SNARES	SN1520I

\* w/ Maple Reinforcement Rings

# SIGNATURE SNARE DRUMS

CAPTURE THE ELUSIVE SOUND OF YOUR DRUMMING IDOL.

# EFFECT SNARE DRUMS

VERSATILE DRUMS FOR SECONDARY EFFECTS.



**CHAD SMITH**



<b>CS1450</b>	<b>SIZE 14" x 5"</b>
SHELL	Steel Shell
HOOPS	SuperHoop II (SH1410B/1410S)
LUGS	CL55
RODS	10
TENSION RODS	SST5047 Stainless Steel
STRAINER	SR015
SNARES	S022
FINISH	Black Nickel



<b>CS1465F</b>	<b>SIZE 14" x 6.5"</b>
SHELL	3 mm Brass / 3 mm Steel / 3 mm Brass
HOOPS	Die Cast (DC1410/1410S)
LUGS	FT65
RODS	10
TENSION RODS	SST5047 Stainless Steel
STRAINER	SR1000F
SNARES	SN1420I
FINISH	Clear Lacquer



- Three interchangeable 3mm rings are housed in Pearl's Free Floating snare frame
- Multiple tonal combinations when stacked in different order
- Total resonant freedom from attachment hardware



**DENNIS CHAMBERS**



<b>DC1450S/N</b>	<b>SIZE 14" x 5"</b>
SHELL	Cast Aluminum: 3mm w/ 2mm R. Rings
HOOPS	SuperHoop II (SH1412B/1408S)
LUGS	STL100
RODS	20
TENSION RODS	SST5047 Stainless Steel
STRAINER	SR020
SNARES	SN1420I
FINISH	Black Nickel Shell w/ Nickel Hardware



**IAN PAICE**



<b>IP1465</b>	<b>SIZE 14" x 6.5"</b>
SHELL	Beaded Steel Shell
HOOPS	SuperHoop II (SH1410B/1410S)
LUGS	TB65
RODS	10
TENSION RODS	SST5042 Stainless Steel
STRAINER	SR017
SNARES	S022
FINISH	Steel



**JOEY JORDISON**



<b>JJ1365N</b>	<b>SIZE 13" x 6.5"</b>
SHELL	Steel Shell
HOOPS	SuperHoop II (SHB1308/1308S)
LUGS	CL65B
RODS	8
TENSION RODS	SST5047 Stainless Steel
STRAINER	SR017
SNARES	S029N
FINISH	Custom Black



**OMAR HAKIM**



<b>OH1350</b>	<b>SIZE 13" x 5"</b>
SHELL	6 ply African Mahogany Shell
HOOPS	SuperHoop II (SH1308/1308S)
LUGS	CL55
RODS	8
TENSION RODS	SST5047 Stainless Steel
STRAINER	SR015
SNARES	S029N
FINISH	#140 Natural Mahogany

## EFFECTS



<b>M1060</b>	<b>SIZE 10" x 6"</b>
SHELL	6 ply Maple
HOOPS	SuperHoop II (SH1006/1006S)
LUGS	CL65
RODS	6
TENSION RODS	SST5035 Stainless Steel
STRAINER	SR018
SNARES	S032N



<b>M1270</b>	<b>SIZE 12" x 7"</b>
SHELL	8 ply Maple
HOOPS	1.6mm Steel (RIM1208B/1208S)
LUGS	CL100
RODS	8
TENSION RODS	SST5047 Stainless Steel
STRAINER	SR018
SNARES	S031N



<b>SFS10/C31</b>	<b>SIZE 10" x 4.5"</b>
SHELL	6 Ply Poplar
HOOPS	1.6mm Steel (RIM1006RSH/RIM1006RSH)
LUGS	MSFL35
RODS	6
TENSION RODS	RSHT3240
STRAINER	SR02MSFL/SR02EMSFL
SNARES	SN10MSFL

## PICCOLO



<b>B1330</b>	<b>SIZE 13" x 3"</b>
SHELL	Brass
HOOPS	1.6mm Steel (RIM1308B/1308S)
LUGS	CL05
RODS	8
TENSION RODS	T055
STRAINER	SR018
SNARES	S029N



<b>S1330B</b>	<b>SIZE 13" x 3"</b>
SHELL	Steel
HOOPS	1.6mm Steel (RIM1308B/1308S)
LUGS	CL05
RODS	8
TENSION RODS	T055
STRAINER	SR018
SNARES	S029N



<b>M1330</b>	<b>SIZE 13" x 3"</b>
SHELL	6 ply Maple
HOOPS	1.6mm Steel (RIM1308B/1308S)
LUGS	CL05
RODS	8
TENSION RODS	T055
STRAINER	SR018
SNARES	S029N

## FIRECRACKER



<b>FCP1250</b>	<b>SIZE 12" x 5"</b>
SHELL	8 ply Poplar
HOOPS	1.6mm Steel (RIM1206/1206SL)
LUGS	CL50
RODS	6
TENSION RODS	T062
STRAINER	SR018
SNARES	S031



<b>FCS1050</b>	<b>SIZE 10" x 5"</b>
SHELL	1.0mm Steel
HOOPS	1.6mm Steel (RIM1006/1006SL)
LUGS	CL50
RODS	6
TENSION RODS	T062
STRAINER	SR018
SNARES	S032



The compact SR018 Strainer features direct-pull geometry for crisp and articulate snare response.

# DEMON DRIVE/CHAIN DRUM PEDALS

THE FASTEST, SMOOTHEST, MOST POWERFUL PEDALS IN THE WORLD.

## THE HARDWARE DRUMTECHS

# Respect



LEVI DICKERSON  
HINDER TECH

WUV  
P.O.D.

CODY HANSON  
HINDER



**SEE AND HEAR**  
DEMON DRIVE & DEMON CHAIN PEDALS  
[pearldrums.com/2minutepedals](http://pearldrums.com/2minutepedals)

FEATURING:  
MIKE REID  
RIHANNA

AREJAY HALE  
HALESTORM

No one knows hardware better than the guys who handle it night after night, city after city. Set it up, tear it down. **EQUIPMENT FAILURE IS NOT AN OPTION, END OF STORY.**

Pearl's hardware is LEGENDARY. So rugged, sure-footed, and built to last that we back it up with PEARL'S EXCLUSIVE Lifetime Warranty.

A choice of 2 positions for a finesse or power feel. Simply loosen the clamshell to change position. U.S. Patent #7579540



INDEPENDENT BEATER ANGLE AND FOOTBOARD HEIGHT ADJUSTMENTS

### P3000D

- (shown in longboard set up)
- P3000D: Single Pedal Complete
- P3002D: Double Pedal Complete (right footed)
- P3001D: Double Pedal Conversion Kit (right footed)
- P3002DL: Double Pedal Complete (left footed)

BEATER HEIGHT ADJUSTMENT  
PERFECT CIRCLE CAM

PIVOTING HOOP CLAMP

NINJA BEARINGS

MULTI FUNCTION DRUM KEY

- P3000C: Single Pedal Complete
- P3002C: Double Pedal Complete (right footed)
- P3001C: Double Pedal Conversion Kit (right footed)
- P3002CL: Double Pedal Complete (left footed)



## DEMON CHAIN

TRADITIONAL FEEL & POWER OF A CHAIN

The Demon Chain pedal combines all of the innovative features of the Demon Drive pedal with all the power, speed, and traditional feel that so many players demand. The Perfect Circle cam provides a smooth consistent response throughout the entire range of the stroke for pinpoint accuracy and control. If you demand the feel of a chain drive in a high performance package, take the Demon out for a test drive.

## DEMON DRIVE

UNLEASH THE DEMON

The Demon Drive is without a doubt the most thoroughly engineered bass drum pedal the World has ever seen. Lightning fast power and silky smooth finesse make this the choice of some of the most prolific drummers in the world. An amazing array of adjustable features turns this pedal into an extension of your body. From beater angle, traction plate grip, and footboard height and angle, it's all your choice. And when you feel the need for speed the Demon quickly converts to a double pedal with a simple add on pack. Unleash the Demon and find out what custom feel is all about.

### P3002D

Direct Drive Double Pedal (shown in longboard setting)



The Click-Lock prevents the tension knob from loosening no matter how hard you play. Simply flip up for adjustment. U.S. Patent #7754953



The Demon Drive beater features a Control Core elastomer center that eliminates unwanted vibration. U.S. Patent #7626108



The two position Direct Link adjusts for a choice of light or heavy feel. This creates the most seamless link between the player's musical ideas and their execution on a bass drum.

The most unique feature of the Demon Drive pedal is Pearl's exclusive Duo-Deck Footboard, the world's first convertible footboard. Through a simple adjustment, the footboard can be adjusted from a traditional shortboard to a longboard pedal in seconds, offering a slightly lighter, quicker feel that is the preferred setup when speed is a necessity. U.S. Patent #7626107

The NINJA Bearings were originally designed by skateboarding engineers. These bearings feature micro-polished steel balls for amazing speed and incredible smoothness.



### P3002C

Chain Drive Double Pedal (shown in shortboard setting)



The Z-Link Drive Shaft features Pearl's exclusive Zero Latency Universal Joints that use precision radial ball bearings and hand-assembled CNC machined frames for zero play and smoothness that allows your slave pedal to respond as quickly and precisely as your primary.



The "linear-response" Perfect Circle Cam provides consistent and smooth feel throughout the entire stroke for pinpoint accuracy and superb control. The racing-inspired Cam is designed to minimize mass and maximize speed and power transfer.



The Demon Chain Pedal is driven by the ultra-lightweight Power Chain with low-friction rollers for speed, and double chain construction for power and dependability. The orange anodized link plates identify the Demon Chain as a member of the Demon family of pedals.

# ELIMINATOR REDLINE PEDAL

THE KEY TO ULTIMATE BASS DRUM PERFORMANCE.

## ELIMINATOR REDLINE

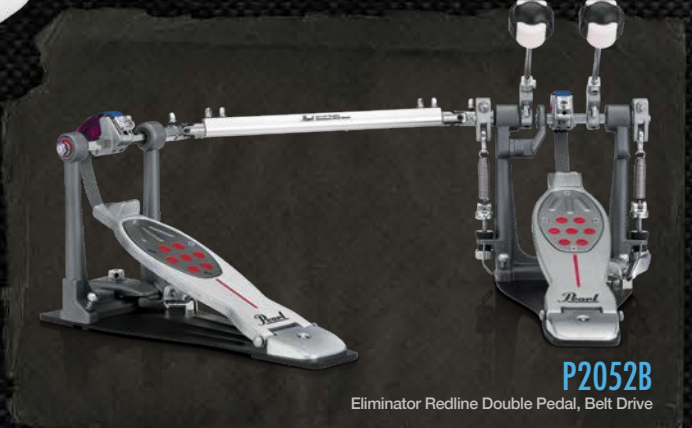

**P2052B**

Eliminator Redline Double Pedal, Belt Drive

### CHOOSE A CAM, REDLINE YOUR PERFORMANCE

Pearl's original PowerShifter Eliminator was a giant leap ahead in bass drum pedals. The world's only pedal featuring the patented Interchangeable Cam System, Eliminator's virtually unlimited tunability lets the player lock in totally personalized feel, power and speed.

The Eliminator: Redline is the next step forward. Like having four pedals in one, Redline fuses the stunning power and flexibility of the original Eliminator with the fluid speed of our Demon series pedals. With a host of radical improvements, Eliminator: Redline helps unlock perfect feel by locking in a cam, further pushing the boundaries of bass drum performance.



Eliminator Redline Series pedals come standard with Custom Carry bags.

**P2050C**

Eliminator Redline Single Pedal, Chain Drive

### ELIMINATOR REDLINE

#### INTERCHANGEABLE CAM SYSTEM US.PAT.#6172291

Pearl's exclusive cam system provides a choice of 6 different color-coded cams (4 included and 2 more optional) allowing you to quickly change the power and feel of the pedal to suit your individual playing needs. Changing from cam to cam is as simple as pushing the release button and snapping another in place.

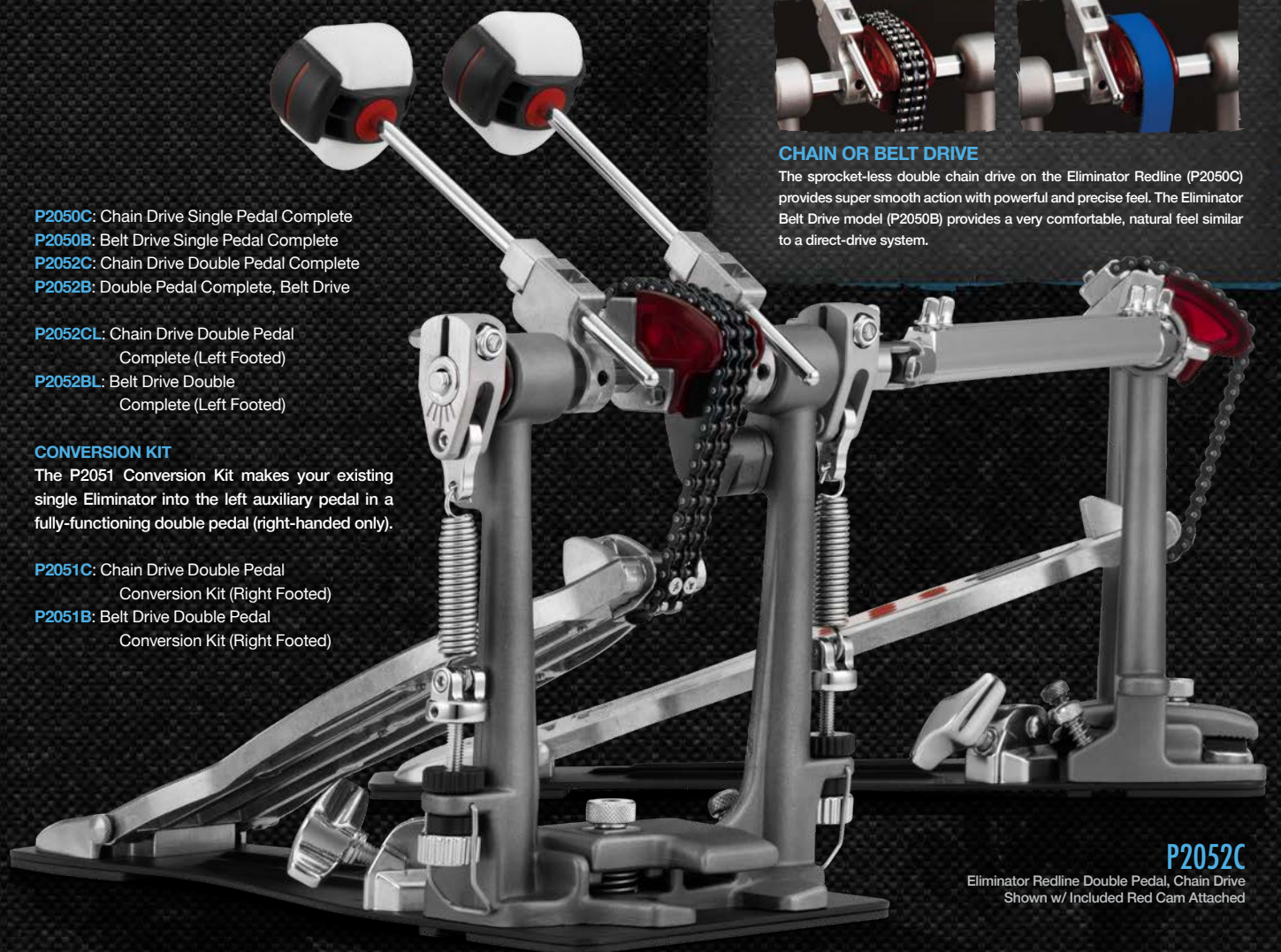
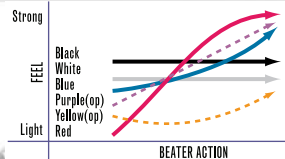

**P2052C**

Eliminator Redline Double Pedal, Chain Drive Shown w/ Included Red Cam Attached



#### CHAIN OR BELT DRIVE

The sprocket-less double chain drive on the Eliminator Redline (P2050C) provides super smooth action with powerful and precise feel. The Eliminator Belt Drive model (P2050B) provides a very comfortable, natural feel similar to a direct-drive system.

- P2050C:** Chain Drive Single Pedal Complete
- P2050B:** Belt Drive Single Pedal Complete
- P2052C:** Chain Drive Double Pedal Complete
- P2052B:** Double Pedal Complete, Belt Drive

- P2052CL:** Chain Drive Double Pedal Complete (Left Footed)
- P2052BL:** Belt Drive Double Complete (Left Footed)

**CONVERSION KIT**  
The P2051 Conversion Kit makes your existing single Eliminator into the left auxiliary pedal in a fully-functioning double pedal (right-handed only).

- P2051C:** Chain Drive Double Pedal Conversion Kit (Right Footed)
- P2051B:** Belt Drive Double Pedal Conversion Kit (Right Footed)



#### INDEPENDENT TRACTION GRIPS

Eliminator Redline's redesigned pedalboard features Pearl's exclusive reversible Traction Plate insert, allowing individual traction grip configuration to suit your exact playing requirements.



#### ZERO PLAY HINGE

Our proprietary stainless steel hinge provides maximum freedom of motion for blazing speed and prevents play between the footboard and heel. U.S. Patent #7179978



#### NiNja BEARINGS

Developed by skateboarding engineers for the ultimate in fast, quiet performance, NiNja Bearings incorporate state-of-the-art micro-polished steel balls for incredibly fast and smooth performance.



#### ROLLER HOOP CLAMP

w/ Side Mount Adjustment. Quickly adapts to a wide range of hoop thicknesses for the smoothest, most secure grip possible. Easy side access to the hoop clamp makes set up and tear down a breeze. U.S. Patent #5726370



#### THE CONTROL CORE QUADBEATER

With a reduced profile, Pearl's improved QuadBeater provides the same four beater surfaces of the original (two hard plastic, two felt) but with the added feel and power of the Control Core elastomer center to eliminate vibration. U.S. Patent #5610351 U.S. Patent #7626108



#### CLICK-LOCK SPRING ADJUSTMENT

w/ NEW Rotor Tension Cradle. Locks the desired spring settings into place and prevents tension creep under play. The counter spring adjustment's rolling cradle allows the spring to pivot with each stroke for less resistance. U.S. Patent #7754953



#### POWERSHIFTER FUNCTION

By moving the footboard forward or back, our revolutionary PowerShifter function provides 3 positions to fine tune the power and feel of the pedal. Instantly change the drive angle leverage to create a light, regular, or strong feel. U.S. Patent #5574237



#### UNI-LOCK BEATER ANGLE CAM

Grips the axel a full 360 degrees and allows infinite beater angle adjustments. Features the Floating Spring Pendulum design that is perfectly centered on the clamp for full bearing movement and maximum smoothness.

# P930/P932 DRUM PEDALS

SPEED & CONTROL FOR THE MASSES.

## SUPER SMOOTH, EXTREMELY FAST!

Pearl's P930 merges many of the advanced features of our Flagship Demon Drive with our Award winning Eliminator line to create a bass drum pedal never before available in this price range.

High end performance inspired from our Demon Drive like the longboard footboard, Control Core beater and our Click-Lock spring tension keepers combine with our PowerShifter and Eliminator style cam technology that uses our Perfect Circle cam with a removable Orange Progressive Cam for fully tunable performance and lightning speed and control.

If you want fast feet and you're on a budget, step up to Pearl's P930 - the ultimate pedal.

### CONTROL CORE DUO BEATER

U.S. Patent #7626108

Our Control Core Beater utilizes our Control Core elastomer center to minimize vibration. It features 2 unique striking surfaces, a slightly rounded felt and a slightly convex hard plastic surface.

### POWERSHIFTER FUNCTION

U.S. Patent #5574237

Our PowerShifter function provides 2 positions to fine tune the power and feel of the pedal. By moving the footboard forward or back, you change the chain angle, thus changing the leverage to create a light, or strong feel.

2 POSITION  
POWERSHIFTER  
FUNCTION

CONTROL CORE BEATER

BEATER HEIGHT  
ADJUSTMENT

INTERCHANGEABLE  
CAM TECHNOLOGY

INFINITE BEATER  
ANGLE ADJUSTMENT

CLICK LOCK  
SPRING TENSION

P930: Single Pedal Complete  
P932: Double Pedal Complete (right footed)  
P931: Double Pedal Conversion Kit (right footed)  
P932L: Double Pedal Complete (left footed)

P930

Single Pedal Complete



SEE AND HEAR  
THE P930 & P932 DRUM PEDALS  
pearldrums.com/2minutepedals

MARK BENNETT  
BARRY'S TECH

BARRY KERCH  
SHINEDOWN



P932

Double Pedal Complete

What's better than double the speed, power and control of our P930? Nothing. The P932 *Demon Deuce* gives the gift of amazing feet for a fraction of the cost of other "less innovative" pedals.



The Orange Progressive Cam can be removed to reveal the Perfect Circle for further tunability to match your playing style. U.S. Patent #6172291

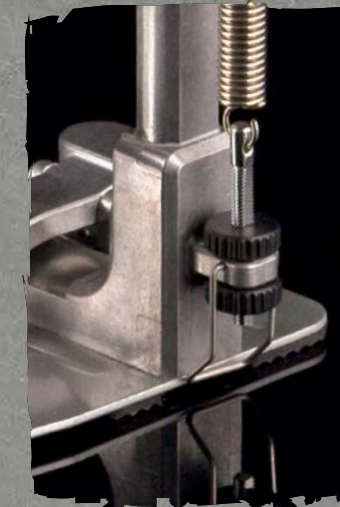

Click-Lock spring tension maintains perfect tension gig after gig. Set it and forget it. U.S. Patent #7754953

The P930 pedal is included as an upgrade in the 830 Series hardware pack and comes with Export and Export Lacquer drum sets.



# HI-HAT STANDS

THE BIGGEST ADVANCEMENT IN TIME KEEPING SINCE THE WRISTWATCH.

JAMES JR. NEWKIRK  
BRIAN'S TECH

BRIAN FRASIER MOORE  
MADONNA



The Super Grip's slip-proof clutch system features a patented 360° lock nut that provides vice-like clamping force for super grip.  
U.S. Patent #7326843 & #7078606

## H2050

- SuperGrip Clutch (U.S. Patent #7326843)
- Hi-Hat Cup (U.S. Patent #7078606)
- Swiveling Legs
- Precision Spring Tension Dial
- PosiLink Twin Cam Drive System with Interchangeable Cams (U.S. Patent #6399866)
- Traction Plate Footboard
- Convertible Spike/Rubber Feet (U.S. Patent #7371953)
- Footboard Docking Station (U.S. Patent #7371952)
- PowerShifter

## H1050

- Direct Pull Drive System
- Infinitely Adjustable Footboard Angle
- Double Braced Tripod w/ Swivel Function
- Spike/Rubber Tips
- Clutch w/Lock Nut (U.S. Patent #7326843)
- Spring Tension Dial
- Hi-Hat Cup (U.S. Patent #7078606)

## RH2050

- Drop Clutch (U.S. Patent #7326843)
- Hi-Hat Cup (U.S. Patent #7078606)
- Precision Spring Tension Dial
- PosiLink Twin Cam Drive System with Interchangeable Cams (U.S. Patent #6399866)
- Traction Plate Footboard
- Reversible Spike/Rubber Feet
- PowerShifter
- Drop Clutch Included

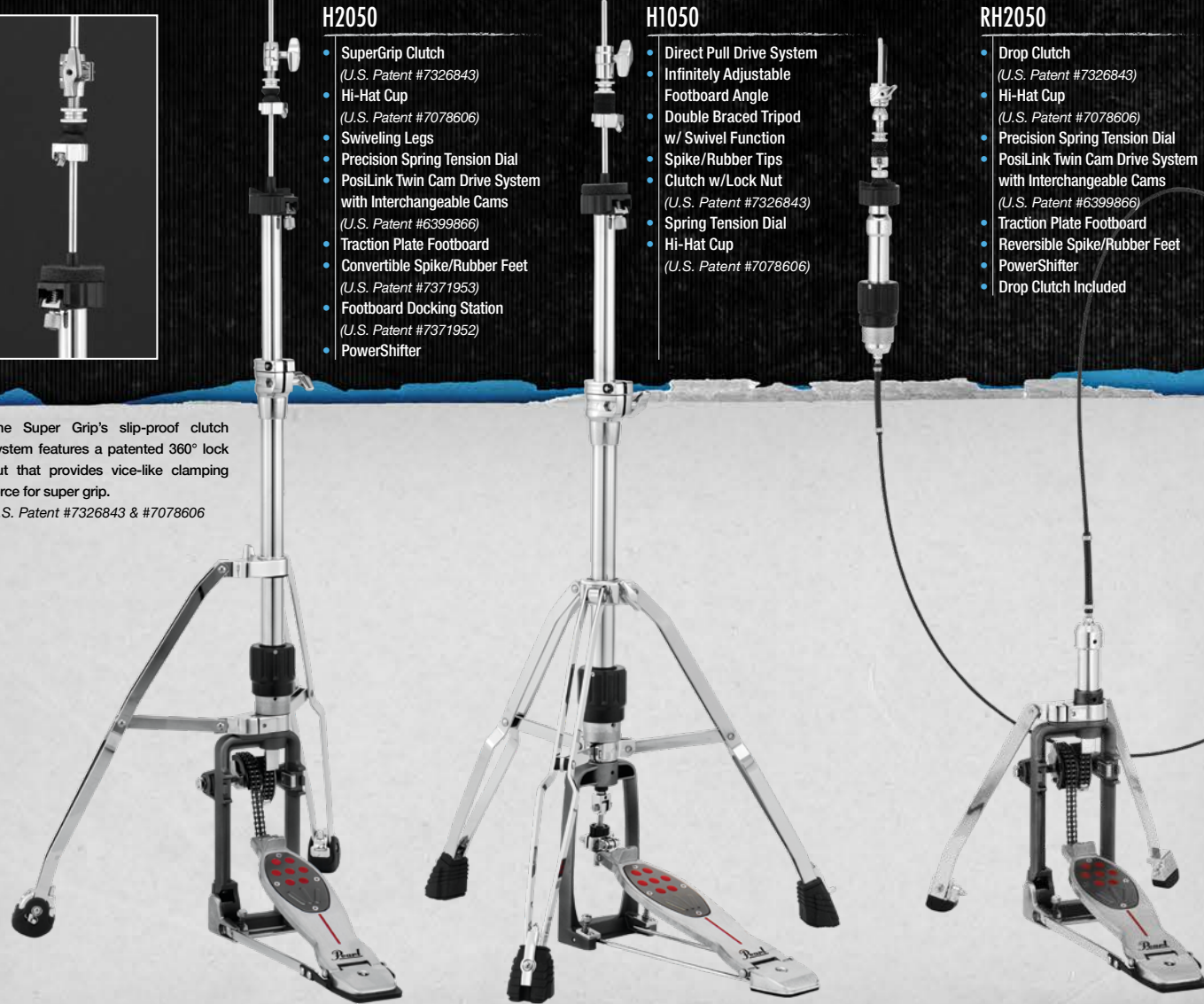

## H930

- Direct Pull Drive System
- Precision Spring Tension Dial
- Double Braced Tripod w/ Swivel Function
- SureGrip Oversize Rubber Feet
- Demon Style Long Board Footboard

## H830

- Demon Style Long Footboard (single color footboard)
- Double Braced Tripod w/ Swivel Function

## H150S

- Light Weight (6.30 lbs.)
- Stable Flat-Based Tripod
- Swivel Function Allows Easy Double-Pedal Positioning
- Direct-Pull Drive System
- Spring Tension Adjustment
- Redline Traction Plate Footboard

## CLH930

- Closed Hi-Hat
- Uni-Lock Tilter
- Knurled Boom Arm
- UltraGrip Wing Nuts / Wing Bolts

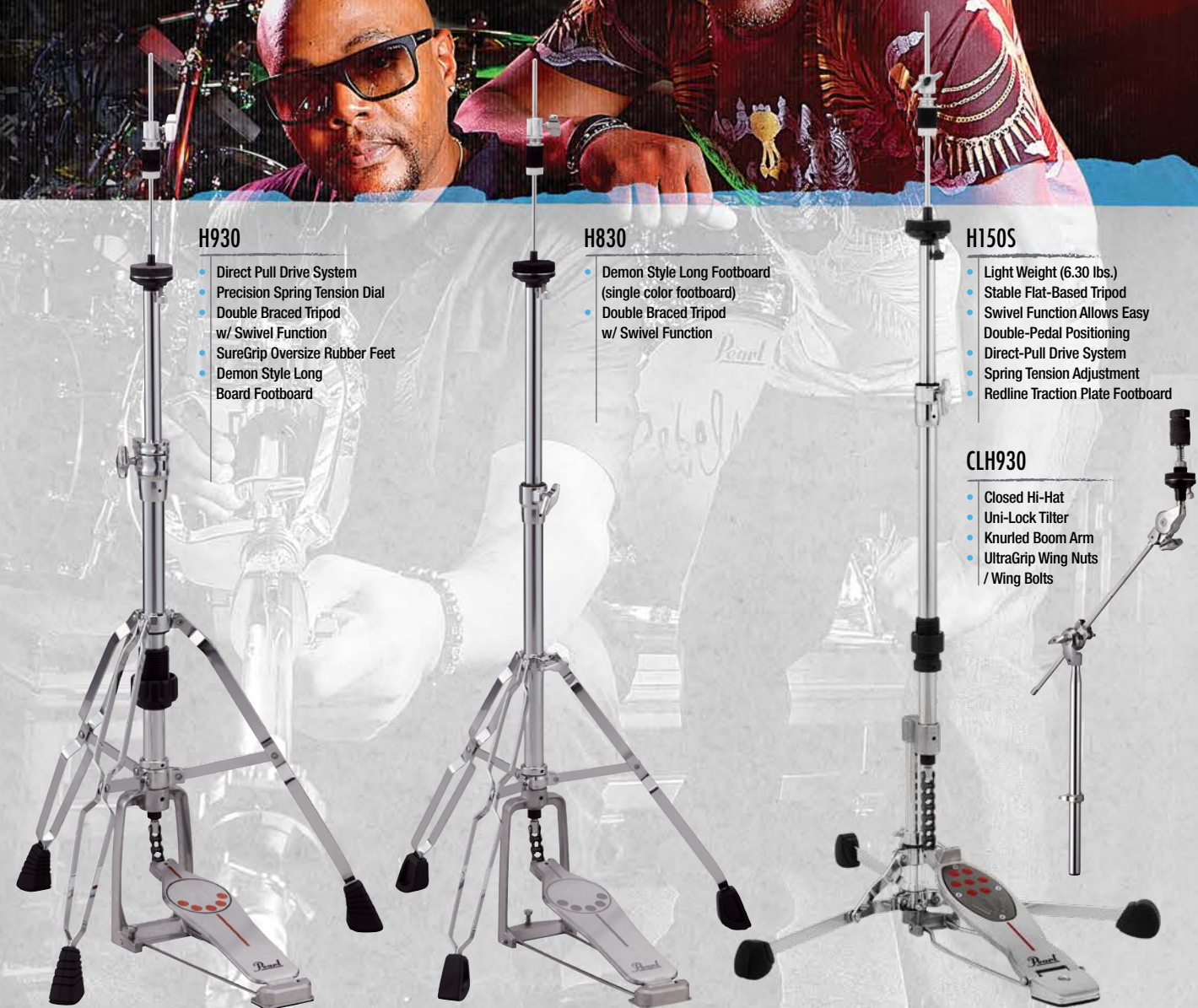

H1050 Pedal Height Adjustment

H1050 Hi-Hat Stand

H930 Hi-Hat Stand

H830 Hi-Hat Stand

H150S\* Flat-Based Swiveling Hi-Hat



\*Toe Stopper Not Included

The H2050 and H1050 features our infinitely adjustable footboard angle adjustment. This allows precise height matching when using multiple pedal setups.

H2050 and H1050 Hi-Hat Stand uses beefy 1" tubing and clamshell clamps with built in memory locks for superior rigidity.

H930 Hi-Hat Stand features our Demon style longboard, double braced tripod w/swivel function, and precision tension dial.

H830 Hi-Hat Stand is standard equipment with our Export series and offers a monochromatic Demon Style longboard design and swivel tripod.

The H150S independent tripod is positioned separately from the pedal frame making it the only flat-based hi-hat stand with swiveling legs.

## INDEPENDENT TRACTION GRIPS

Like all Eliminators, the pedal has removable traction grip inserts that can be adjusted or removed to tailor the amount of grip or slip. The plate is even reversible for more choices.



The H2050 Precision Spring Tension Dial allows absolute perfect tension control for the ultimate in fine-tunable response.



HA130

Sharing many of the key characteristics of new Eliminator Redline bass drum pedals, 2050 Series Hi-Hat Stands deliver unparalleled versatility and customization in hi-hat pedal control. The world's-only hi-hat stand featuring the Interchangeable Cam System, 2050 Series stands' customizable options are designed to eliminate resistance, reduce fatigue, and increase performance.

The RH2050 Remote Hi-Hat's low-friction cable produces smooth, lag-free performance with the lightning-fast action of the PosiLink Twin Cam drive system. Fast, natural-feeling cymbal play is finally accessible virtually anywhere on the kit, or to facilitate multiple hi-hat system setups.

The HA130 positions your hi-hat next to your bass pedal in double bass set-ups for super quick transitions between pedals.

# SNARE STANDS

EVERY SNARE SHOULD BE SO LUCKY.

Our premiere S1030 model offers chameleon like diversity for stage or studio. Rock solid footing with a GyroLock tilter that allows pinpoint positioning. The basket arms promote optimal resonance with the Air Suspension cradle.



## S1030 SNARE STAND GYROLOCK

Our premier S1030 model features Pearl's 360 degree infinitely adjustable GyroLock tilter for ease-of-use and pinpoint positioning.



## S1030 SNARE BASKET

The Pearl S1030 Snare Stand adjusts to fit virtually any size snare from 10" to 16". The Air Suspension rubber tips securely cradle your prized snares while allowing them to fully resonate. U.S. Patent #6710236



## S930D SNARE BASKET

The S930D Snare Stand is a shorter version of the S930 Snare Stand, and is built to comfortably accommodate deeper snare drums.

## SPIKED / RUBBER FEET

Our CVT300/3 Push Button Spiked/Rubber Feet come in pack of 3 to retrofit on any of our 1030 Series hardware for sure-footed performance on any terrain. U.S. Patent #7371953

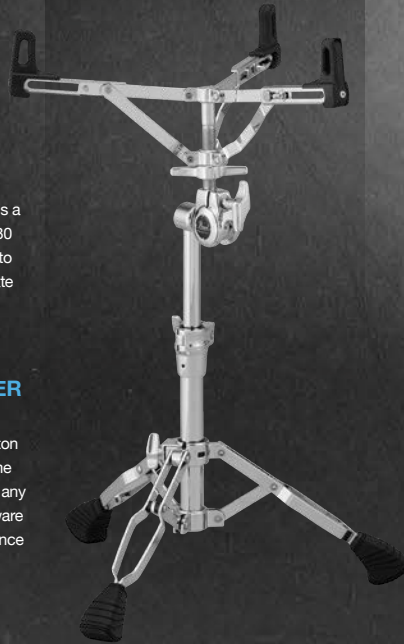

The S930 offers similar features but uses our legendary Uni-Lock tilter and is also available as a drop basket version.

Our S830 model is standard equipment with our all new Export line. Lightweight, yet rigidly strong, it's perfect for the local gig and makes load in at the club a breeze.

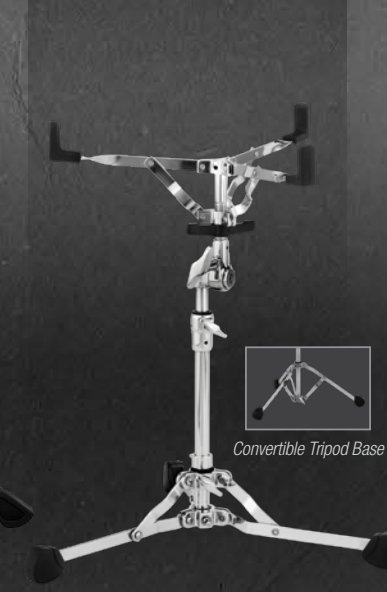

Convertible Tripod Base

# DRUM THRONES

SOUND ERGONOMICS.



SHAUN FOIST  
BREAKING BENJAMIN

NICK THIEME  
SHAUN'S TECH

## S1030

- GyroLock Tilter
- Air Suspension Rubber Tips (U.S. Patent #6710236)
- Trident Tripod
- Oversize Super Grip Rubber Feet
- Fits Snares 10"-16"
- Height Range of 470-660mm

## S930

- Uni-Lock Tilter
- Air Suspension Rubber Tips (U.S. Patent #6710236)
- Double Braced Trident Style Tripod
- Fits Snares 10"-14"
- Height Range of 450-630mm

## S930D

- Drop Basket for Deeper Snares
- Uni-Lock Tilter
- Air Suspension Rubber Tips (U.S. Patent #6710236)
- Double Braced Trident Style Tripod
- Fits Snares 10"-14"
- Height Range of 360-540mm

## S830

- Uni-Lock Tilter
- Double Braced Tripod
- Fits Snares 13"-14"
- Height Range of 430-620mm

## S1505

- Light Weight (5.18 lbs.)
- Stable Flat-Based Tripod
- Gearless Uni-Lock Basket Tilter
- Convertible Tripod or Flat-Based Legs

## D1000SN (Not shown)

Same as below but in a "short" version 455-625mm



## D2500BR

- Motorcycle-Style Cushion
- Detachable Backrest
- Mounts via Single Knob
- Reversible Stoplock Collar
- Height Range of 495-665mm

## D2500

- Motorcycle-Style Cushion
- Accepts Backrest
- Reversible Stoplock Collar
- Height Range of 495-665mm

## D1000N

- Round Vinyl Cushion
- Reversible Stoplock
- Height Range of 495-665mm



The D1000SPN Series features a firm vinyl covered cushion and a shock absorbing post for outstanding comfort, along with adjustable spring tension for customizable support.



D2500 and D1000 Series Thrones are equipped with Pearl's exclusive Lock/Spin System. By reversing the StopLock, the cushion can be locked to prevent turning or allowed to spin depending on your preference.



The Height Collar features a hinged Stop Lock and vise-like clamshell design for non-slip security.



## D1000SPN

- Round Vinyl Cushion
- Built In Shock Absorber Post with Adjustable Spring Tension
- Reversible Stoplock
- Height Range of 525-630mm

## D930

- Round Vinyl Cushion
- Double Braced Legs
- Height Range of 470-660mm

## D790

- Round Vinyl Cushion
- Height Range of 450-650mm

## D730S

- Round Vinyl Cushion
- Single Braced Tripod
- Height Range of 400-580mm

Next to your drums your throne could be your most important piece of gear. A great throne will prevent fatigue, promote great form and posture to keep you going for those second and third encores night after night. Our thrones offer advanced ergonomic design, sturdy wide footprints for stability and a wide selection of cushion tops to provide your desired level of softness or firmness.

# BOOM/STRAIGHT CYMBAL STANDS

WELCOME TO BOOM TOWN.

Pearl's BC2030 features patent pending Nodal Point Markings on the telescopic tubes that allow cymbals to achieve better clarity and sustain when the tubes are positioned at their respective Nodal Points.



Your hardware has to work as hard as you do. Sometimes it's what separates good drummers from the great. Our hardware is road-ready and street-wise. Strong, rigid and durable yet incorporating sophisticated refinements and innovations. Our BC2030 is the most technically advanced boom stand ever devised. It's perfect for the studio musician and offers an unbelievable range of positioning for your prized cymbals.

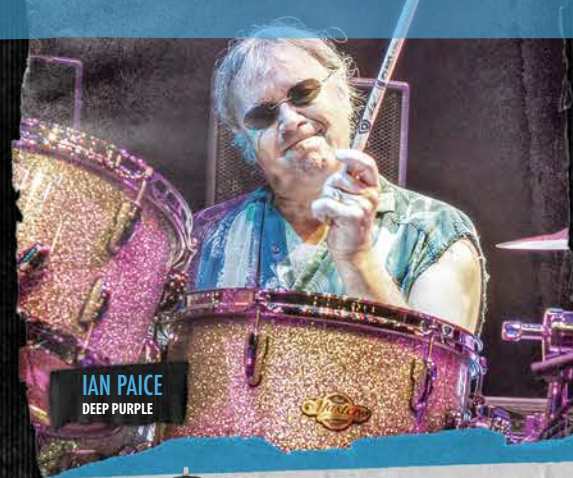

IAN PAICE  
DEEP PURPLE

## FOR EVERY CYMBAL, THERE IS A PLACE.

Nothing takes more abuse than your cymbal stands.

Constant practice, tear 'em down throw 'em in the back of your ride, load 'em in at the gig. Abuse 'em a couple of hours on stage then start all over again. Those clamps and tilters take a lot of abuse that's why Pearl is the choice of the serious working drummer. We've been advancing drum hardware since 1946 so if you're serious about drumming, get serious about your hardware.

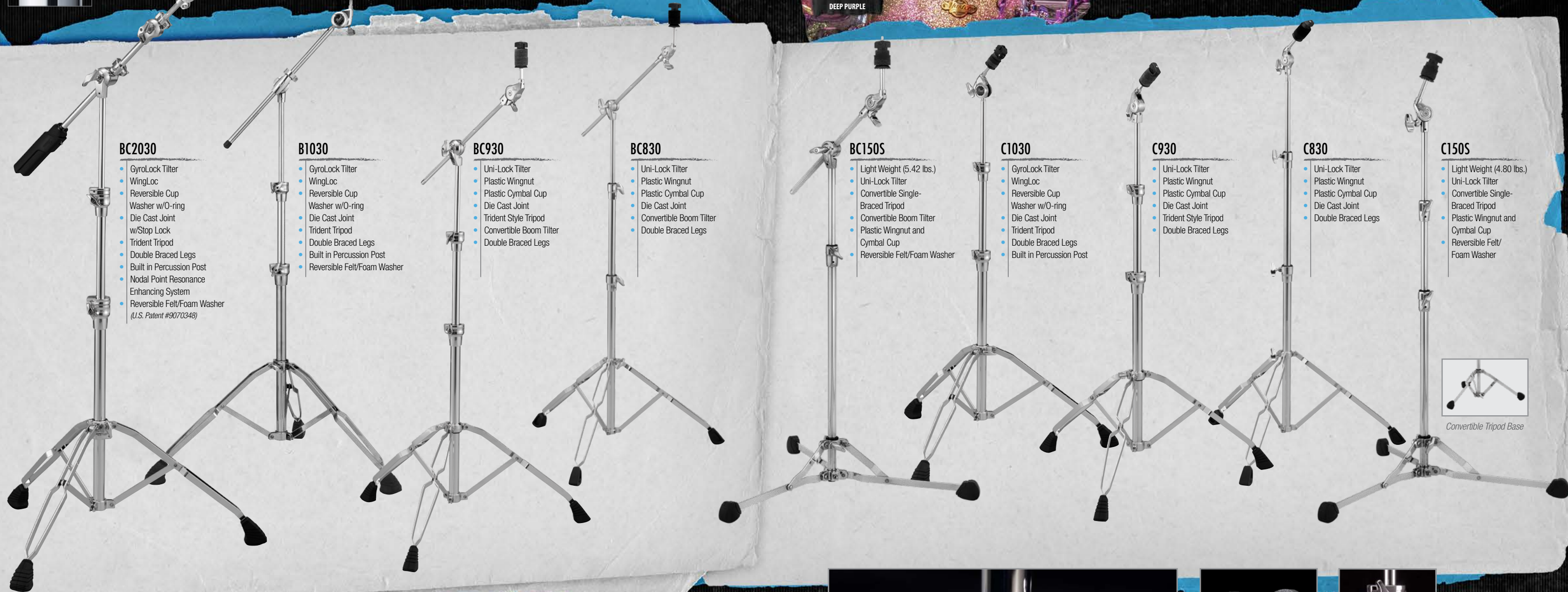

### BC2030

- GyroLock Tilter
- WingLoc
- Reversible Cup Washer w/O-ring
- Die Cast Joint w/Stop Lock
- Trident Tripod
- Double Braced Legs
- Built in Percussion Post
- Nodal Point Resonance Enhancing System
- Reversible Felt/Foam Washer (U.S. Patent #9070348)

### B1030

- GyroLock Tilter
- WingLoc
- Reversible Cup Washer w/O-ring
- Die Cast Joint
- Trident Tripod
- Double Braced Legs
- Built in Percussion Post
- Reversible Felt/Foam Washer

### BC930

- Uni-Lock Tilter
- Plastic Wingnut
- Plastic Cymbal Cup
- Die Cast Joint
- Trident Style Tripod
- Convertible Boom Tilter
- Double Braced Legs

### BC830

- Uni-Lock Tilter
- Plastic Wingnut
- Plastic Cymbal Cup
- Die Cast Joint
- Convertible Boom Tilter
- Double Braced Legs

### BC150S

- Light Weight (5.42 lbs.)
- Uni-Lock Tilter
- Convertible Single-Braced Tripod
- Convertible Boom Tilter
- Plastic Wingnut and Cymbal Cup
- Reversible Felt/Foam Washer

### C1030

- GyroLock Tilter
- WingLoc
- Reversible Cup Washer w/O-ring
- Die Cast Joint
- Trident Style Tripod
- Double Braced Legs
- Built in Percussion Post

### C930

- Uni-Lock Tilter
- Plastic Wingnut
- Plastic Cymbal Cup
- Die Cast Joint
- Trident Style Tripod
- Double Braced Legs

### C830

- Uni-Lock Tilter
- Plastic Wingnut
- Plastic Cymbal Cup
- Die Cast Joint
- Double Braced Legs

### C150S

- Light Weight (4.80 lbs.)
- Uni-Lock Tilter
- Convertible Single-Braced Tripod
- Plastic Wingnut and Cymbal Cup
- Reversible Felt/Foam Washer



Convertible Tripod Base



GyroLock Tilters are infinitely adjustable and provide 360 degree range of motion for precise positioning with one-step convenience.



The Trident Tripod uses a full 360° of clamping force via the hinged collar. The inner tube rests in a nylon bushing to prevent metal to metal contact. Heavy duty legs feature lateral bracing for superior ultra quiet rigidity.

#### WingLoc (U.S. Patent # 6884015)

Pearl's WingLoc Quick Release Wing Nut snaps open and snaps closed for super quick removal and attachment.

#### Reversible Seat Cup (U.S. Patent #6940006)

The seat cup is specially designed to "float" normally or it can be reversed and "locked" to prevent noise during recording.



830 Series stands offer lighter weight while incorporating many of the 1030 series designs. The tripod uses Trident style design with double braced legs. Large easy to use wingnuts and lateral struts for optimal stability.

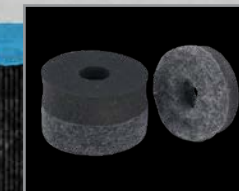

The Reversible Felt/Foam Cymbal Washers allow four-way control of cymbal "ring" by mixing and matching the "hard" and "soft" surfaces of the washers.



The Clamshell designed Die Cast joint on 2030, 1030, 930 series Boom and Straight cymbal stands, provides superhuman clamping force. Set your position, lock it down and wail away.



# RACKS + TOM STANDS / ARMS

AN INDUSTRY ICON - THE PROFESSIONAL'S CHOICE.

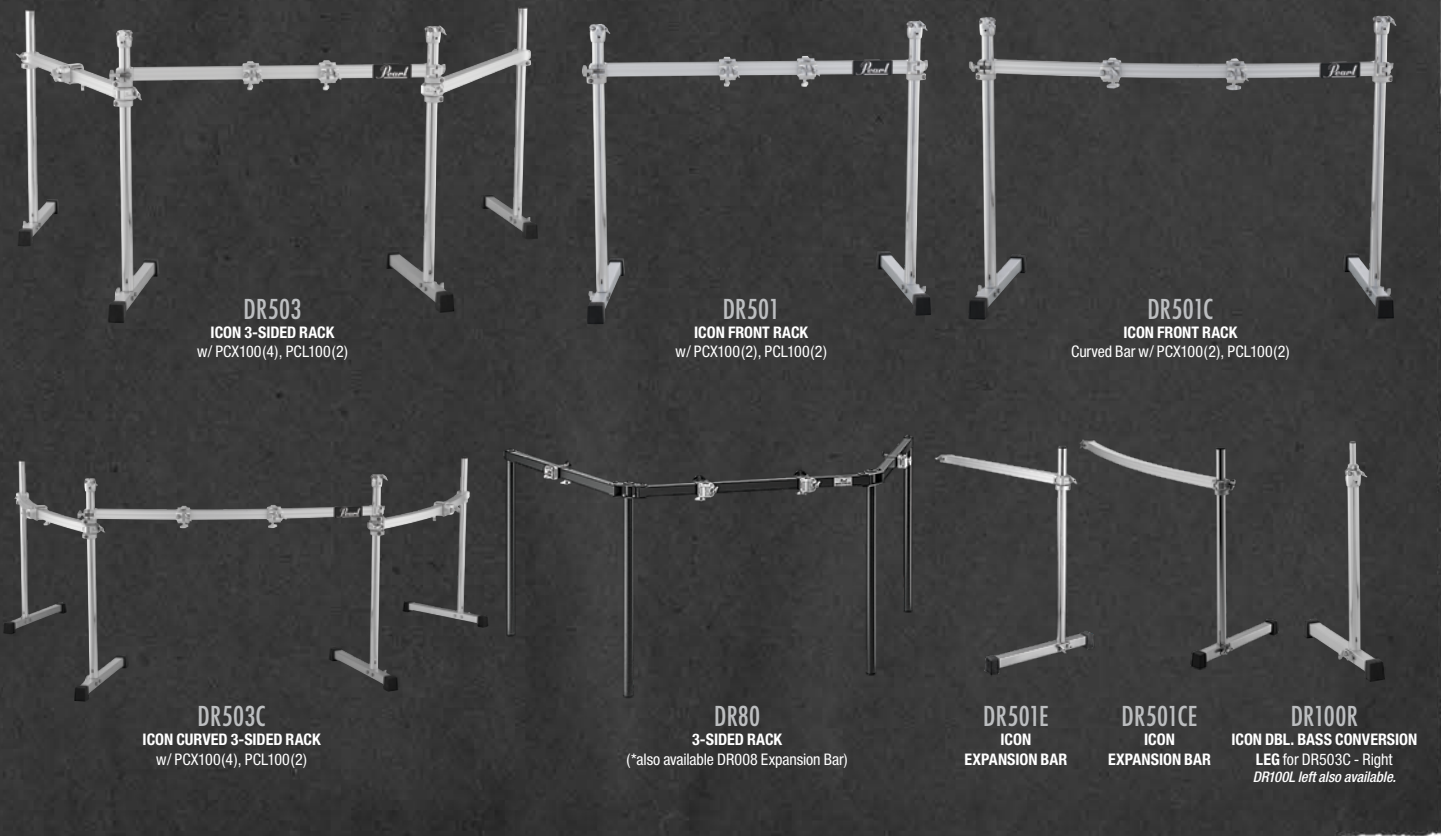

**DR503**  
ICON 3-SIDED RACK  
w/ PCX100(4), PCL100(2)

**DR501**  
ICON FRONT RACK  
w/ PCX100(2), PCL100(2)

**DR501C**  
ICON FRONT RACK  
Curved Bar w/ PCX100(2), PCL100(2)

**DR503C**  
ICON CURVED 3-SIDED RACK  
w/ PCX100(4), PCL100(2)

**DR80**  
3-SIDED RACK  
(\*also available DR008 Expansion Bar)

**DR501E**  
ICON EXPANSION BAR

**DR501CE**  
ICON EXPANSION BAR

**DR100R**  
ICON DBL. BASS CONVERSION  
LEG for DR503C - Right  
DR100L left also available.



**PCX100 PIPE CLAMP**  
Clamp System  
w/ Adjustable Jaw



**PCX200 PIPE CLAMP**  
Tilting Clamp System  
w/ Adjustable Jaw



**PC8 PIPE CLAMP**  
fits 7/8" tubes, for DR80



**RJ50 ICON**  
6" MINI-EXPANSION BAR



**RJ100 PIPE JOINT**  
for DR100L / DR100R



**PCL100 PIPE CLAMP FOR LEG**  
fits all ICON Rack Leg Posts



**ADP20\***  
2 Clamps  
fits 5/8"-1-1/8"

**AX25\***  
2 Revolving Clamps  
fits 1/2"-1-1/8"

**AX25L\***  
2 Revolving Clamps  
fits 1/2"-1-1/8"

**AX28\***  
In-Line & Revolving Clamps  
fits 5/8"-1-1/8" & 1/2"-1-1/8"

**ADP30\***  
fits 3/8"-1-1/4"  
3 Adjustable Clamps

\*Stands & Tom Arms not included

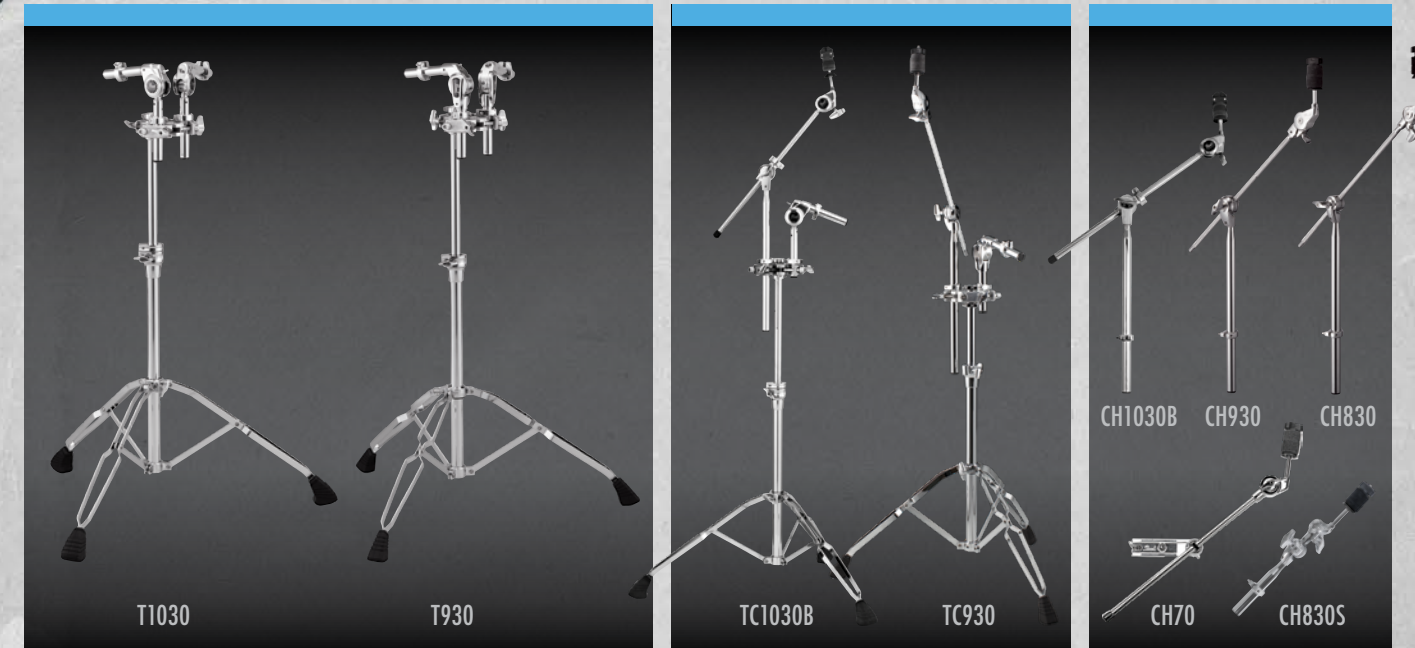

T1030

T930

TC1030B

TC930

CH1030B

CH930

CH830

CH70

CH830S



**PMBDL3/C**  
CHROME MULTI BASS DRUM LEGS

Multi-Bass Drum Legs allow any bass drum to be played horizontally. Height and tilt adjustable. (Patent Pending)



TH1030 TOM ARMS

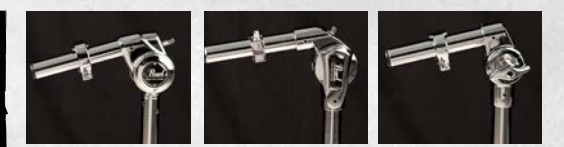

GYROLOCK

UNI-LOCK

GEAR TILTER

Pearl's Tom Arms offer positioning possibilities never before attainable. Our T/TC1030 Series features our GyroLock tilter for an infinite 360 degree range of movement. The T/TC930 Series use our Uni-Lock tilter for 180 degrees of motion. Our TH88 and TH70 Tom Arms Series use our dependable gear tilter.

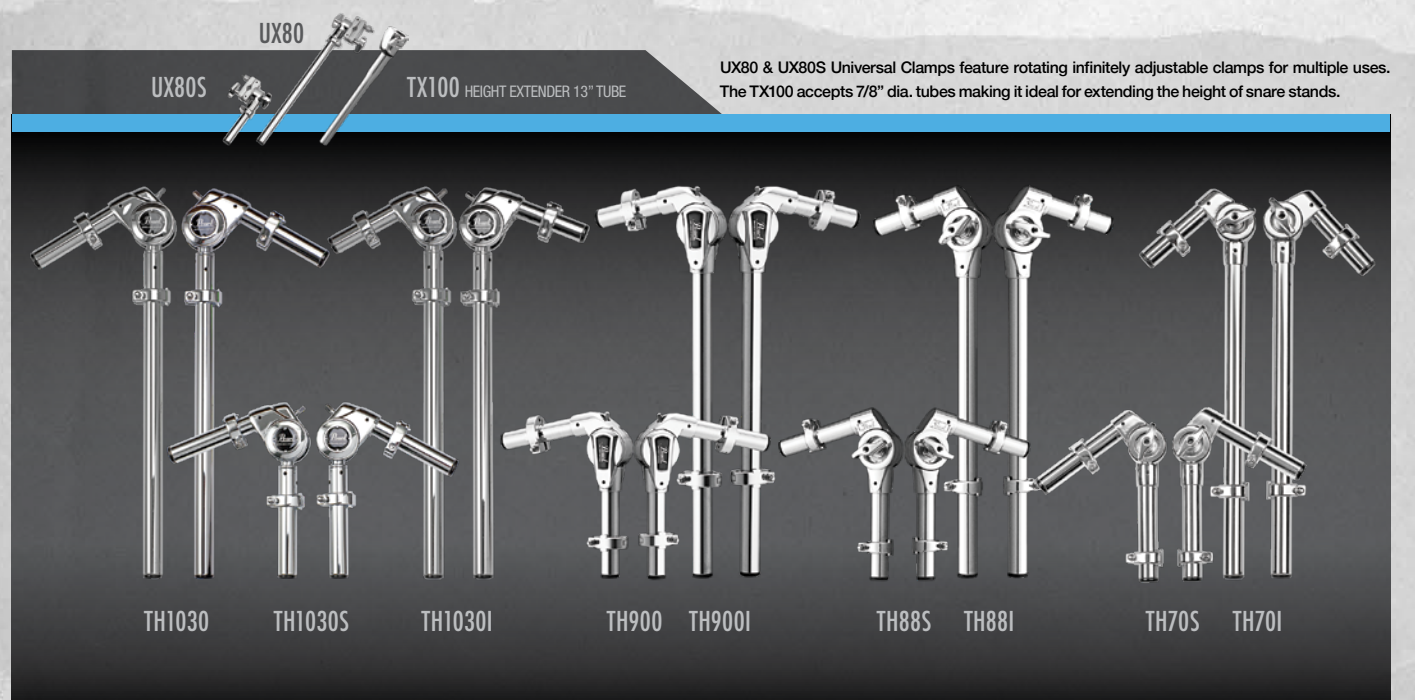

UX80S

UX80

TX100 HEIGHT EXTENDER 13" TUBE

UX80 & UX80S Universal Clamps feature rotating infinitely adjustable clamps for multiple uses. The TX100 accepts 7/8" dia. tubes making it ideal for extending the height of snare stands.

TH1030

TH1030S

TH1030I

TH900

TH900I

TH88S

TH88I

TH70S

TH70I

# SIGNATURE CONGAS + BONGOS

## THE PROS PLAY PEARL!

### PEARL CONGAS

#### BOBBY ALLENDE

Bobby Allende Signature Fiberglass Congas and Bongos  
#618 Brisa Tropical



**CONGAS**  
PCF110DXBA 11" QUINTO  
PCF117DXBA 11.75" CONGA  
PCF125DXBA 12.5" TUMBA

**BONGOS**  
PBF300DXBA 7" & 9"

#### RICHIE FLORES

Richie Flores Signature Oak Congas and Bongos  
#527 Lunar Eclipse



**CONGAS**  
PCW110DXRF 11" QUINTO  
PCW117DXRF 11.75" CONGA  
PCW125DXRF 12.5" TUMBA

**BONGOS**  
PBW300DXRF 7" & 9"

Pearl has congas to meet the needs of every player from seasoned professionals to beginners. Our Elite Series offers the highest quality heads with polished Contour Crowns and a choice of shell materials: 100% aged Thai Oak or seamless Fiberglass. Our Primero Pro line features professional-quality construction at an affordable price and a choice of 100% Thai Oak or Fiberglass. The Primero line features outstanding Pearl quality along with the same choice of 100% Thai Oak or Fiberglass. Pearl's Signature Congas feature Contour Crown Rims, polished chrome hardware, and exclusive Self-Aligning Washer System for truly optimal performance. Each series is offered with matching Bongos, and is available in 100% Thai Oak or seamless Fiberglass shells.



**ELITE FIBERGLASS CONGAS**  
PCF110DXA 11" QUINTO  
PCF117DXA 11.75" CONGA  
PCF125DXA 12.5" TUMBA

**ELITE FIBERGLASS BONGOS**  
PBF300DXA 7" & 9"  
#641 Blue Sparkle Burst

### ELITE SERIES



**ELITE OAK BONGOS**  
PBW300DX 7" & 9"  
#532 Cherry Eucalyptus

**ELITE OAK CONGAS**  
PCW110DX 11" QUINTO  
PCW117DX 11.75" CONGA  
PCW125DX 12.5" TUMBA  
#532 Cherry Eucalyptus

**ELITE OAK BONGOS**  
PBW300DX 7" & 9"  
#535 Satin Black w/  
Gold Hardware

**ELITE OAK CONGAS**  
PCW110DX 11" QUINTO  
PCW117DX 11.75" CONGA  
PCW125DX 12.5" TUMBA  
#535 Satin Black w/ Gold Hardware

### FIELD PERCUSSION SERIES



**FIELD PERCUSSION CONGAS**  
PFC202EDU649 10" & 11" Congas  
#649 Textured Black

### HAVANA SERIES

The exotic Red Tiger Strip finish is accentuated with gold plated hardware for a look that is as bold as the sound of the Havana Series.

The wide belly shape of these high end, fiberglass drums produce deeper low tones and greater volume. Contour Crown rims and natural skin heads give you clear highs and cutting slaps.



#644  
Liquid Gold

The stunning Liquid Gold finish and chrome plated hardware completes a set of drums you can love forever.

**HAVANA CONGAS**  
PCF110HV651 11" Havana Quinto  
PCF117HV651 11.75" Havana Conga  
PCF125HV651 12.5" Havana Tumba

**HAVANA BONGOS**  
PBF300HV651 7" & 9" Havana Bongos  
#644 Liquid Gold  
#651 Red Tiger Stripe

### TRAVEL CONGAS



Pearl Travel Congas are available in three standard sizes: 11" x 3.5", 11.75" x 3.5" and 12.5" x 3.5". They feature wood shells and stave construction and Remo FiberSkyn 3 synthetic heads. Five precision Allen bolts provide accurate and easy tuning via the included foam-handle wrench. The Travel Conga stand is designed specifically to be rock solid, and lightning fast during set-up and pack-up. The stand comes with a carrying bag that includes a pocket for the optional PPS50TC Bridge that connects two stands together to minimize creeping while performing.

PTC1100 11" TRAVEL CONGA  
PTC1175 11.75" TRAVEL CONGA  
PTC1250 12.5" TRAVEL CONGA  
PSC1175TC Travel Conga Bag

PC1100TC STAND FOR 11" w/ CARRYING BAG  
PC1175TC STAND FOR 11.75" w/ CARRYING BAG  
PC1250TC STAND FOR 12.5" w/ CARRYING BAG  
PPS50TC STAND BRIDGE



**TRILOK GURTU** INDEPENDENT  
**FRANK KNUCKLES** THE ROOTS  
**LALO DAVILA** MTSU  
**PAPO PEPIN** CONGA LEGEND  
**ROLANDO MORALES MATOS** THE LION KING  
**ANDY FARAG** UMPHREYS MCGEE  
**DOMINIQUE THOMAS** JILL SCOTT  
**COUNT M'BUTO** THE DEREK TRUCKS BAND



**ARCHIE PEÑA** SHAKIRA  
**CESAR ESPINOZA** ORCHESTRA TOBACO Y RON  
**VALERIE DEE NARANJO** SATURDAY NIGHT LIVE  
**CARMELO TORRES** LOS LONELY BOYS  
**BRETT BAKER** JAY-Z  
**AARON DRAPER** ADELE / EMINEM / RIHANNA



# CAJONS+ACCESSORIES

GET IN THE CAJON ZONE!

Cajons are the perfect introduction to the world of percussion. Affordable, easy to carry and just plain fun to play. Pearl offers a diverse collection of Cajons with a complete selection of accessories to customize your instrument and develop your own unique sound. Perfect for drum circles, small gigs or even studio work, your Cajon will become your new best friend.



## CAJON ACCESSORIES

Enhance your performance by adding dynamic new sounds. Jingle Cups can be added to the face of any Cajon or even to acoustic guitars and other drums. The Cajon Clave and Wood Blocks attach to your cajon using the provided 3M Dual-Lock Tape or can be played hand-held or stand mounted. The Cajon seat cushion adds comfort for long sessions.

**NEW!**



**SAMBAJON**  
PCJSBJ  
This Fiberglass cajon has two playing surfaces: a traditional hardwood front faceplate and a padded, cloth covered side that produces a Brazilian Surdo / "808" style bass tone. Perfect for use with any cajon pedal.  
Black Lacquer Finish

**NEW!**



**3D CAJON**  
PBC53D  
The 3D Cajon features 3D, CNC-cut graphics on the sides of the hardwood body. Internal snares are raised to create a larger bass strike zone. Inside the faceplate is coated with clear lacquer for a crispy snare response.  
Black and Natural Finish



**CYCLONE CAJON**  
PCJ647CYC  
When you hit this rounded back, fiberglass beauty and the air funnels around and exits the bass port resulting in a fat, throaty bottom. The flexible wood faceplate provides a crisply articulate voice with remarkable projection.



100° Ergonomic Playing Position



**CENTIGRADE CAJON**  
PCJ650CG  
This Fiberglass cajon features a front faceplate with 100 degrees of angle for less stress on your lower back. The molded rear bass port projects a full, rich bass tone.  
#650 Mango Cherry Burst



**INNER CIRCLE MULTI DRUM CAJON**  
PCJIC645  
Sit on top for standard cajon playing, or unlatch, remove and place drum on the closed cajon and play like a conga at a seated height. Or attach the accompanying strap and you have a shoulder-slung djembe or Timbao.



**CAJH100**  
Cajon Holster Nylon w/ Velcro Straps



**PSEBC**  
Seat Cushion w/ Thick Foam for Comfort



**CLUB CAJON**  
PBC5512CC  
The Club cajon features all wood construction with fixed snares and a rear facing bass port that deepens the lows.  
#512 Sheer Black finish



**PRIMERO JINGLE\***  
PBC507JC  
The Primero Jingle is a wood version of the Jingle cajon and features built in Platinela and tambourine jingles that allow you to sound like an entire percussion section.  
#507 Gypsy Brown finish



**WEDGE TRI-SIDE CAJON**  
PCJ3000B  
This unique pie slice shape offers a natural seated playing position and 2 striking surfaces. Fiberglass construction with fixed snares and Artisan II finish. Ported in rear.



**JESUS DIAZ SIGNATURE RADIAL EDGE CAJON**  
PBC509JD  
In conjunction with world-renowned percussionist Jesus Diaz, Pearl has created the Radial Edge Cajon. Its high-end wood construction, fixed snares and luxurious Artisan Rosewood finish make this the ultimate cajon experience possible.



**BRUSH BEAT CAJON**  
PCJ633BT  
Fiberglass construction with textured surface that responds well to brushes and other effects. Ported in rear.  
Black and White Finish



**PBCW100**  
Wood Block w/ Dual-Lock Tape & Mounting Bracket (PPS37 Not Included)



**PCJP1/6**  
Jingle Cup Two Pack



**PBCCT00**  
Clave Block w/ Dual-Lock Tape & Mounting Bracket (PPS37 Not Included)



**BOOM BOX CAJON**  
PCJ633BB  
This Fiberglass cajon with fixed snares features a built in bass port that magnifies subsonic frequencies for great bass projection.  
#633 Artisan Red Mahognay



**PRIMERO BOX CAJON\***  
PBC507  
Get started with Primero. Constructed from Asiatic Pine with snares, this model has the right pitch and price.  
#507 Gypsy Brown finish



**BOOM BOX CAJON**  
PCJ633BB630  
This Fiberglass cajon with fixed snares features a built in bass port that magnifies subsonic frequencies for great bass projection.  
#630 Red Sparkle



**JINGLE CAJON**  
PCJ629  
This Fiberglass cajon features built in Platinela and tambourine jingles that can be engaged for incredible sound with fixed snares.  
#629 Carubinga finish



**FUN BOX CAJON**  
PFB300  
Help your child develop proper playing mechanics while playing this smaller kid-friendly size cajon. Durable Fiberglass construction finished in bright yellow.

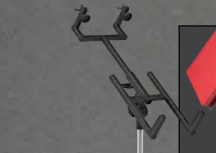

**PCJ70STD**  
Cajon Stand

**NEW!**



**SONIC BOOM FLAME THROWER CAJON\***  
PBC1914FT  
Made In The USA. Features a Flame Maple faceplate that adds a new voice to the Sonic Boom family. Two strategically placed base ports are located at the top on the back to increase snare projection. Fiery Red and Natural Finish.



**SONIC BOOM\* BZZ**  
PBC1914SB  
Made in the USA. A massive low-end producer perfect for small acoustic settings or larger amplified venues. 100% Birch construction provides exceptional resonance that speaks clearly through the frontward facing bass port. This Box Rocks!



**SONIC BOOM BZZ\***  
PBC1914SB  
Sister to the popular Sonic Boom, the Buzz adds fixed snares and a resonant Artisan Walnut front plate. This beautiful cajon really has the deep bass and punchy snare crack you need to emulate a drum set.



**MACH 3 CAJON\***  
PBC1914M3  
Made in the USA. The Mach 3 features a 100% Birch body with three isolated playing zones that simulate snare, bass and tom sounds. The backwards tilted front plate provides a comfortable playing position.

**NEW!**



**MACH 2 CAJON\***  
PBC511MS  
Made In The USA. The Birch snare section of the faceplate creates a bright response while the Walnut bass section provides a punchy low end. An internal resonance plate prevents unwanted crosstalk between the sound chambers.  
#511 Natural Finish



**AFTERBURNER CAJON\***  
PBC511ABC  
Made in the USA. The Afterburner cajon features dual rear-firing ports that resemble the exhaust on a classic hot rod and delivers the same low end rumble. The 100% Birch body has a premium grain natural finish.

Dual Rear-Firing Ports

# TIMBALES + COWBELLS + FRAME DRUM PERCUSSION

BUILD THE RIGHT RIG FOR THE GIG!

MARC QUIÑONES  
GREGG ALLMAN

HORACIO HERNANDEZ  
INDEPENDENT

## TIMBALES



PTSS134  
PRIMERO TIMBALES  
13" / 14" Steel w/ Tilting Stand  
(Stands & Cowbell included)



PTE1415DX  
PRIMERO PRO TIMBALES  
14" / 15" Steel w/ Tilting Stand  
(Sticks included. Cowbell not included.  
Not available in Europe)



ETE1415MQ  
MARC QUIÑONES SIGNATURE TIMBALES  
14" / 15" Steel w/ Tilting Stand and  
PBL-30 Clave Block (Cowbell not included)

## BANDA SERIES



PBTM1516/C  
BANDA TIMBALES  
15" / 16" Steel w/ Tilting Stand



PBTB2418/C33  
BANDA TAMBORA  
24" x 18" Bass w/ Cymbal Mount, Stand & Mallet



JOSE ROSA  
MIAMI INDEPENDENT

SAMMY GARCIA  
INDEPENDENT

MARCO "ITO" ARGUINZONI  
TITO NIEVES

CARLITO SOTO  
WILLIE COLON



PTE1336  
PRIMERO 13"  
STEEL TIMBALE  
w/ PPS36 Mount



PTE3131  
FLAT TIMBALE  
w/ I.S.S. (Steel)



PTB3131  
FLAT TIMBALE  
w/ I.S.S. (Brass)

## HORACIO HERNANDEZ SIGNATURE COWBELLS



HH5X MARYBELL    HH4X ISABELL    HH3X CHABELLA    HH2X CLABELL    HH1X BELLA



Pearl and Grammy Award winning artist Horacio Hernandez have developed the ultimate family of cowbells. These bells feature a quick release system that allows the bell to lift easily off of its mount for hand held playing. 5 unique pitches make this the perfect family.

## NEW YORKER BELLS



BCM3NY CHA-CHA (High)    BCM5NY CHA-CHA (Low)    BCM7NY MAMBO    BCM8NYQ MARC QUIÑONES SIG. TIMBALE BELL

## PRIMERO COWBELLS



PCB10MCR 10" MILLENNIUM CHROME BELL    PCB1030 10" BELL w/ PPS-30    PCB6 6" BELL    PCB4 4" BELL

## BALA BELLS



BCM10 MOUNTED CAMPANA BELL    BCH10 HAND-HELD CAMPANA BELL



PTB30 TRI-BELLS    ECB22 HAND-HELD AGOGO    ECB23 MOUNTED AGOGO    PTA30 TRI AGOGO    PDC60 PRO COWBELL BEATER



**FRAME DRUMS** • Pearl Frame Drums are solid wood construction with tuneable coated heads that allow you to create various tones.

RAFA PEREIRA  
JANELLE MONAE



PFR14HK\*  
HIP KIT 14" Frame Drum  
w/ Hip Clipz Snare & Strap

The Pearl Hip Kit combines a 14" frame drum and accessory pack that is perfect for drum circles, the stage, studio or as a cocktail kit.



PFR14C  
14" FRAME DRUM



PFR0818C  
FRAME DRUMS Set of 6  
Sizes: 8", 10", 12", 14", 16", 18"

The Hip Clipz accessories can convert any frame drum into the ultimate wearable, go anywhere drum.



PHCSTRP HIP CLIPZ STRAP    PHCSNR HIP CLIPZ SNARE    PHC-PK HIP CLIPZ PACK



JOSE APONTE  
UNT



RAVI JAKHOTIA  
RAVI DRUMS



CHRISTIAN PEPIN  
INDEPENDENT

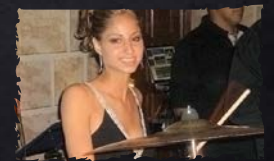

JESSICA RODRIGUEZ  
COCOMAMA

# DJEMBES + FOLKLORIC PERCUSSION

ANCIENT INSTRUMENTS FOR THE MODERN PERCUSSIONIST.

**DJEMBES** • Djembes are a traditional African instrument that offer a wide variety of sounds and are perfect for drum circles. The Professional Elite Series is available in Oak (12.5" diameter) and Fiberglass (12.5" and 14" diameter). All feature our Contour Crowns for comfortable playing and authentic Goat skin heads for deep lows and crisps highs.



PJW140R533 EZ TUNE DJEMBE 14" (OAK) #533 Gloss Black  
 PJW125R533 EZ TUNE DJEMBE 12.5" (OAK) #533 Gloss Black  
 PJF320RX632 EZ TUNE DJEMBE 12" (FIBERGLASS) #632 Cranberry Fade  
 PJF350RX632 EZ TUNE DJEMBE 14" (FIBERGLASS) #632 Cranberry Fade  
 PJF350FP649 FIELD PERCUSSION DJEMBE 14" (FIBERGLASS) #649 Textured Black Remo NuSkyn Heads  
 PJW340 ELITE OAK DJEMBE 12.5" #511 Natural (Not available in Europe)  
 PJF350 14" PJF320 12.5" ELITE FIBERGLASS DJEMBE #602 Bistre Black (Not available in Europe)  
 PFD300 FIBERGLASS FUN DRUM

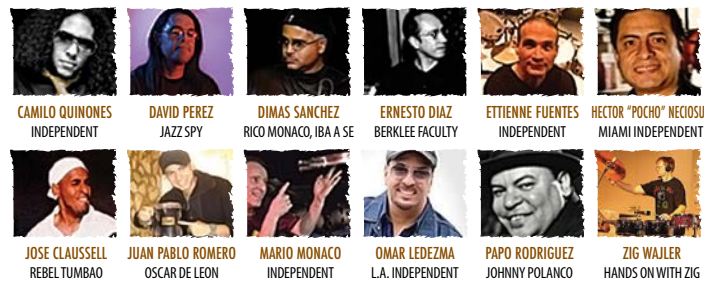

CAMILO QUINONES INDEPENDENT  
 DAVID PEREZ JAZZ SPY  
 DIMAS SANCHEZ RICO MONACO, IBA A SE  
 ERNESTO DIAZ BERKLEE FACULTY  
 ETTIENNE FUENTES INDEPENDENT  
 HECTOR "POCHO" NEGOSIP MIAMI INDEPENDENT  
 JOSE CLAUSSSELL REBEL TUMBAO  
 JUAN PABLO ROMERO OSCAR DE LEON  
 MARIO MONACO INDEPENDENT  
 OMAR LEDEZMA L.A. INDEPENDENT  
 PAPO RODRIGUEZ JOHNNY POLANCO  
 ZIG WAJLER HANDS ON WITH ZIG



PJBS350 DJEMBASS

**DJEMBASS** • If you want extreme low-end, and a head-turning alternative to a standard bass drum, look no further than to Pearl's Djembass. Convert our most popular PJF350 Fiberglass Djembe into a compact kick drum with the Djembass accessory pack. To reduce the attack and add greater "lows" we have included a cloth cap that stretches around the head. For greater low-end, slip the included neoprene disc inside which give you two sound options. Your pedal (not included) attaches via an I.S.S. type clamp to the Djembe's stand mounting plate.

**FOLKLORIC ELITE CONGAS** • Pearl's line of Folkloric congas feature a traditional look with modern innovation that only Pearl can deliver. Each 28" tall Oak conga is designed for the "seated" player, but is pre-drilled for stand mounts if necessary. Thicker South American style natural skins makes the drums warm sounding, but a fiberglass gel coat on the interior seals the shell and adds the projection and volume desired by today's players. Four Polished Steel Reinforcing Bands are inset on the shell for a smooth touch, and the traditional hoops complete these stunning instruments in a Matte Crimson Sunrise finish. The 7 & 8.5" Oak Bongos have the same hardware and shell features of the congas. The thicker bongo skins add to the projection and "dry" tone reminiscent of that classic Cuban sound.



PCW125FC TUMBADOR 12.5"  
 PCW110FC QUNITO 11"  
 PCW117FC SEGUNDO 11.75"  
 PBW300FC FOLKLORIC ELITE BONGOS 7" & 8.5"



PBA60 ITOTELE  
 PBA70 IYA  
 PBA50 OCONOLO

**BATAS** • Pearl Percussion Bata drums are available in Crimson Sunrise, the same beautiful finish featured on our Folkloric Elite congas and bongos. Additionally, the hardware is finished in Polished Steel and matches the hardware on our other tunable hand drums. These sacred ceremonial instruments have a thicker Enu (large) head for a deep, rich tone.

## SHEKERS



PCA14FC CATA W/ HOLDER  
 PAC10FC ACHERE  
 PGT10FC GUATAKA  
 PCL10FCB BAMBOO CLAVE  
 PCL20FCW WOOD CLAVE



PSK50FC UNO  
 PSK60FC SEGUNDO  
 PSK70FC CAJA

# BRAZILIAN + CONCERT PERCUSSION

DISCOVER SAMBA!

## BRAZILIAN PERCUSSION

Pearl's line of Brazilian Percussion brings modern refinements and Pearl quality to the traditional Samba musician. Our Repinique features lightweight yet sturdy steel shells with etched heads, shoulder straps and low rims for incredible playing comfort. The lightweight wood shell Surdos allow for hours of comfortable play when worn over the shoulder with the provided strap. Available in 18"x22", 20"x18" and 22"x22" sizes (diameter x depth), Pearl's popular Surdos continue to be the industry standard. The Timbao is made from lightweight fiberglass, and is capable of the extremely high tension utilized in tradition Brazilian ensembles. The Rocar is equipped with brass and steel platinellas, and can be played as a single shaker, or separated for two-handed sonic options.



PBTB140 TIMBAO  
 PBT1420 TAN TAN  
 PBS2018 SURDO 20"  
 PBS1822 SURDO 18" (Shown with optional PBS-30BD)  
 PBS2222 SURDO 22"



PBS30BD LEGS & BD ADAPTER KIT FOR SURDO  
 PBT705 TAMBORIM STICK  
 PBSM20 SURDO Mallet  
 PBR80 ROCAR



PBCX1204 CAIXA 12"  
 PBCX1265 CAIXA 12"  
 PBC80SS CUICA  
 PBR105 REPINIQUE 10" w/ Strap  
 PBR125 REPINIQUE 12" w/ Strap  
 PBP510 PANDEIRO 10" (5 sets platinellas & goatskin head) w/ bag  
 PBP612 PANDEIRO 12" (6 sets platinellas & plastic head) w/ bag  
 PDZ510 PANDANZA w/ Agogo Bell  
 PBT60C TAMBORIM w/ Quick Draw Mount

## CONCERT PERCUSSION

Pearl is proud to offer Concert Percussion instruments that are attractively priced for school ensembles, yet engineered with the professional percussionist in mind. The symphonic tambourine is a perfect example. Its 17 pairs of specially aged, stamped brass jingles provide a dry, yet bright tone that brings added color to any musical situation.

Its 10" headed wood frame allows the player to effortlessly perform all tambourine techniques, and the tambourine's plush carrying case is included. The rattler is another vital component to any concert percussionists' equipment, and Pearl's is built with an extended handle for a comfortable grip and ease of playing. Holders for the rattler and castanets are also available.



WST20FP FIELD PERCUSSION 10" SHIME TAIKO  
 PCN20S CASTANETS  
 PCN20H CASTANETS HOLDER  
 PSS100 SLAP STICK  
 PCW8100 (High)  
 PCW200A (Medium)  
 PCW300A (Low)  
 PPS12T STIX-FREE TRIANGLE HOLDER w/ 8" Triangle  
 PET100 10" TRIANGLE  
 PET80 8" TRIANGLE  
 PET60 6" TRIANGLE  
 PTC10 TRIANGLE CLIP  
 PTC300 TRIO TRIANGLE HOLDER  
 PRT10C RATTLER MOUNTING CLAMP  
 PCWT805 TEMPLE BLOCKS  
 PRT10 RATTLER

# HAND PERCUSSION

A WORLD OF HAND PERCUSSION.

NOTE: Items pictured are not to scale



**PNG20** NATURAL GOURD GUIRO  
**PMG20** METAL GUIRO  
**PFM20** BEADED MARACAS  
**PFM50** MARACABASA  
**PGA20** BASKET GANZÁ 9" x 4"



**PGA60FP** 21" FIELD PERCUSSION SHAKER  
**PGA32 (Long) PGA30 (Short)** HEX GANZÁS  
**PGA40** TRIPLE SHAKER  
**PGA50SF** GROOVE SHAKER  
**PEC1** EGG CARTON



**PTM09BK** 9" PRIMERO ROCK TAMBOURINE W/ MILLENNIUM JINGLES  
**PTH10B (Brass) PTH10S (Steel)** HEADLESS WOOD TAMBOURINES  
**PTM10GH** TAMBOURINE W/ BRASS JINGLES  
**PTM10SH** STEEL JINGLE TAMBOURINE W/ STAINLESS STEEL JINGLES  
**PTM50BHR (Brass) PTM50SHR (Steel, not pictured)** ULTRA GRIP VOLUME ADJUSTABLE TAMBOURINE



**CBS100** GATLING CABASA  
**PTG20** TANG-TANG  
**PAB20 (High) PAB50 (Medium) PAB100 (Low)** ASH TONE BLOCKS  
**PBL10 (High) PBL20 (Medium) PBL30 (Low)** CLAVE BLOCK (High) CLAVE BLOCK (Medium) CLAVE BLOCK (Low)



**PWR40** SHAKELETS  
**PSC30** SPIRIT CHIMES W/ HOLDER & Mallet  
**PWCH3620A** 36 ANODIZED ALUMINUM BARS WITH CASE, HOLDER AND STRIKER  
**PWCH3220G** 32 GOLD ANODIZED ALUMINUM BARS WITH CASE, HOLDER AND STRIKER

# PERCUSSION STANDS, BAGS + HOLDERS

PRO TOOLS FOR EVERY GIG.

## PERCUSSION STANDS & BRACKETS

The PC3000TW stand holds full size professional congas as securely as most stands double its weight and mass. The PC300W is scaled down to support our lighter Primero Conga line-up. Both stands set-up in seconds because there are no wingnuts needed to mount your congas. The PC2500 Ultralite Conga stand, is lightweight yet sturdy and stable. Index markings on all adjustable parts make for consistent lightening fast set-ups.



**CONGA STANDS**  
**PC3000TW** QUICK RELEASE DOUBLE CONGA STAND W/ BAG  
**PC900** ALL-FIT CONGA STAND  
**PC200** PRIMERO TWIN CONGA STAND  
**PC300W** QUICK RELEASE DOUBLE CONGA STAND  
**BONGO STANDS**  
**PB900LW** ALL-FIT TILTING BONGO STAND  
**PB700** LIGHTWEIGHT BONGO STAND  
**PB700BHS** BONGO ATTACHMENT FOR PC-200  
**DJEMBE STAND**  
**PC800S** ALL-FIT DJEMBE STAND

## TRAP TABLE & RACK

Our popular PTT1824 Trap Table can be easily converted into a two-level folding rack without drilling or modifications by simply adding the PTR1824 Add-On Rack. The PTR1824 installs in seconds using clamps and folds flush with the table for easy pack-up. A unique clamping system allows the included (4) straight and (4) angled 3/8" knurled posts to clamp anywhere onto horizontal or vertical areas of the rack. Also included is a retractable three-legged stabilizer bar for optimum stability. The easy-to-attach PTR-UNV Universal Trap Table Rack mounts on virtually any trap table and features six 3/8" rods and receptors for various percussion mounting possibilities.



**PTRUNV** UNIVERSAL TRAP TABLE RACK (Table & stand sold separately from rack)  
**PTT1824** TRAP TABLE (18" x 24")  
**PTT1824 + PTR1824** TRAP TABLE RACK  
**PTR1824RC3** TRAP TABLE SINGLE POST ADAPTER  
**PTT1212** TRAP TABLE (12" x 12")  
 (FOR PTT1824, PTT1212)

## PERCUSSION CASES

Features include: ergonomic carrying straps, rubber protective bottoms, top-mounted carrying handles, tuning wrench pouches, & heavy duty double zippers.



**PSC8B** BONGO BAG  
**PSC125CG** CONGA BAG 12.5"  
**PSC117CG** CONGA BAG 11.75"  
**PSC110CG** CONGA BAG 10"  
**PSC140DJ** DJEMBE BAG 14"  
**PSC125DJ** DJEMBE BAG 12.5"  
**PSC1213CJ** BOX CAJON CASE  
**PSC2000** ULTRA LITE CONGA STAND CASE  
**PSC1175TC** TRAVEL CONGA CASE

## HOLDER + ACCESSORIES



**PTYB1212** PERCUSSION TOY BOX (accessories not included)  
**PPS37** ANGLED POST ADAPTER  
**PPS40** LUG MOUNT ACCESSORY HOLDER  
**PGH20** UNIVERSAL GUIRO HOLDER  
**PPS20** FOOT PEDAL BRACKET  
**PCS10** COWBELL STACKER  
**PPS10 & PPS11** STIX-FREE  
**CA130**  
**75H**  
**75X**  
**PPS81**  
**PPS82** COWBELL HOLDERS

# REPLACEMENT PARTS

## ULTRA-SOUND SNARES

Pearl's Ultra-Sound snares feature patented Graduated Tension wires for extended dynamic range from ultra soft to ultra loud. Ultra-thin, low mass end plates assure ultra quick response. The end plates feature three mounting options: tunnels or holes for cord mounting and slots for straps.



SN1320C	20 strands for 13", C-type, w/straps & cords
SN1320D	20 strands for 13", D-type, w/straps & cords
SN1320I	20 strands for 13", I-type, w/straps & cords
SN1420C	20 strands for 14", C-type, w/straps & cords
SN1420D	20 strands for 14", D-type, w/straps & cords
SN1420I	20 strands for 14", I-type, w/straps & cords



SN1442C	42 strands for 14", C-type, w/straps & cords
SN1442D	42 strands for 14", D-type, w/straps & cords
SN1442I	42 strands for 14", I-type, w/straps & cords

## REPLACEMENT SNARES



S022N	20 Strand for 14" w/Cords
S022NU	20 Strand for 14" w/Cords, Uncoated
S022	20 Strand for 14" w/Straps
S025	20 Strand for 14" long, w/Straps
S029N	20 Strand for 13" w/Cords
S030N	24 Strand for 14" w/Cords
S031N	20 Strand for 12" w/Cords
S032N	12 Strand for 10" w/Cords
S033N	12 Strand for 12" w/Cords
S040	15 Strand for 14" w/Cords, Steel Cable, Thinner Gauge
S041	15 Strand for 14" w/Cords, Bronze Cable, Thicker Gauge
SPS18/6	Plastic Strap (6/pkg)
SNC40/6	Snare Cord (6/pkg)

## OPTI-LOC



Opti-Loc suspension tom holders provide exceptional stability while greatly improving resonance and sustain. (For EXX / EXL Export / DMP)

OPL0608/C	Opti-Loc for EXX and DMP 6"-8" Diameter
OPL1216/C	Opti-Loc for EXX and DMP 12"-16" Diameter

## OPTIMOUNT

Our OptiMount Suspension System attaches to the tom's tension rods and floats on rubber cushions, providing the ultimate in stability while allowing the drum to resonate fully without restriction. With OptiMount, the mounting hardware is completely removed from the drum shell, providing a drastic improvement in resonance and sustain.



OPTA0708/C	for drums 7"-8" deep, 6"-16" diameter, Light Weight Aluminum	OPT0708	for drums 7"-8" deep, 8"-16" diameter, UltraGrip Wingnut
OPTA0910/C	for drums 9"-10" deep, 6"-16" diameter, Light Weight Aluminum	OPT0910	for drums 9"-10" deep, 8"-16" diameter, UltraGrip Wingnut
OPTA1112/C	for drums 11"-12" deep, 6"-16" diameter, Light Weight Aluminum	OPT1112	for drums 11"-12" deep, 8"-16" diameter, UltraGrip Wingnut
OPTA1314/C	for drums 13"-14" deep, 6"-16" diameter, Light Weight Aluminum	OPT1314	for drums 13"-14" deep, 8"-16" diameter, UltraGrip Wingnut
OPTA1516/C	for drums 15"-16" deep, 6"-16" diameter, Light Weight Aluminum	OPT1516	for drums 15"-16" deep, 8"-16" diameter, UltraGrip Wingnut

## MASTERCAST HOOPS

MasterCast are the finest die cast hoops available and feature the perfect blend of thickness and mass to improve the depth, clarity, and focus of toms and snare drums.



Model #	Diameter	# of Tension
DC0805	8"	5
DC1006	10"	6
DC1206	12"	6
DC1306	13"	6
DC1408	14"	8
DC1408S	14"	8 Snare Side
DC1410	14"	10
DC1410S	14"	10 Snare Side
DC1410SG	14"	10 Snare Side w/Guard
DC1508	15"	8
DC1608	16"	8
DC1808	18"	8

## BASS DRUM HOOP PROTECTORS



HPP2	Metal Hoop Protector for Wood BD Hoops
NP01	Hoop Protector for Metal BD Hoops
NP347/2	Non-Slip Hoop Protector for Wood BD Hoops (pair)

## SUPER HOOP II & FATONE HOOPS

SuperHoop II hoops are precision formed from heavy-duty 2.3mm steel, triple-flanged and engraved with the SuperHoop II logo. FatTone hoops are low mass 1.6mm hoops with hemmed and welded edges for strength and rigidity.



Super Hoop Model #	FatTone Hoop Model #	Diameter	# of Tension
SH0604	NA	6"	4
SH0805	FH0805	8"	5
SH1006	FH1006	10"	6
SH1006S	NA	10"	6 Snare Side
SH1206	FH1206	12"	6
SH1208	NA	12"	8
SH1208S	NA	12"	8 Snare Side
SH1306	FH1306	13"	6
SH1308	FH1308	13"	8
SH1308S	FH1308S	13"	8 Snare Side
SH1408	FH1408	14"	8
SH1408S	NA	14"	8
SH1410	FH1410	14"	10
SH1410S	FH1410S	14"	10 Snare Side
SH1410SG	NA	14"	10 Snare Side w/Guard
SH1508	FH1508	15"	8
SH1608	FH1608	16"	8
SH1808	FH1808	18"	8

## STEEL HOOPS

Steel Hoop Model #	Diameter	# of Tension
RH0804	8"	4
RH1006	10"	6
RH1206	12"	6
RH1306	13"	6
RH1408	14"	8
RH1408S	14"	8 Snare side
RH1608	16"	8
RH1808	18"	8

## MASKING COVERS

The GK90 and BBC1 cover the holes of BT3 and BB3 brackets that have been removed.



BBC1 for BB3, w/Gasket, Screws and Nuts  
GK90 for BT3, inside/outside plates w/Bolts

## SPIN-TIGHT™ TENSION RODS

Specially-designed stainless steel tension rods that lock to maintain tension settings. Starter pack includes 4 Spin-Tight Tension rods with K180 Drum Key.



K180	
SPT5047	W7/32 x 47mm (1)
SPT45PK	W7/32 x 47mm (4) w/ K-180 Drum Key
SPT6PK	W7/32 x 47mm (6)

## STAINLESS STEEL TENSION RODS

Pearl's Stainless Steel Tension Rods are machined, not forged, from a single piece of stainless steel to the most exacting tolerances in the industry. They feature super-smooth, precise tensioning, with absolutely no play. Each non-plated stainless steel tension rod is matched with a precision-machined brass swivel nut for ultra-precise performance.

SST5028/6	W7/32 x 28mm (6)
SST5035/6	W7/32 x 35mm (6)
SST5038/6	W7/32 x 38mm (6)
SST5042/6	W7/32 x 42mm (6)
SST5047/6	W7/32 x 47mm (6)
SST5052/6	W7/32 x 52mm (6)

## TENSION ROD WASHERS

NLW12B/12	Metal Washers (12)
MTW12/12	Nylon Washers (12) Black
MTW12/12	Metal Washers (12)

## TENSION ROD LOCKNUTS

TNK10N/10	Tension Rod Lock Nuts (10/pkg)
TL20/10	Tension Keeper (10/pkg)

## CAMS + BEATER WEIGHT

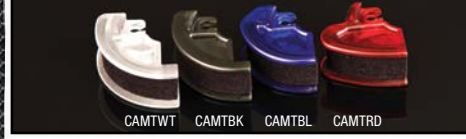

EPAP1 Package: Beater Weight, Purple Cam, Yellow Cam  
BW100 Beater Weight, 3 Weights in One (U.S. Patent #7122730)  
P2000 SERIES CAMS  
CAMPL Eliminator Purple Cam, Aggressive Action  
CAMYL Eliminator Yellow Cam, Inverse Action  
CAMBK Eliminator Black Cam, Linear Action  
CAMWT Eliminator White Cam, Oversized Linear Action  
CAMBL Eliminator Blue Cam, Progressive Action  
CAMRD Eliminator Red Cam, Radical Action

P2050 SERIES CAMS  
CAMPL Eliminator Purple Cam, Aggressive Action  
CAMYL Eliminator Yellow Cam, Inverse Action  
CAMTBK Eliminator Translucent Black Cam, Linear Action  
CAMWT Eliminator Translucent White Cam, Oversized Linear Action  
CAMTBL Eliminator Translucent Blue Cam, Progressive Action  
CAMTRD Eliminator Translucent Red Cam, Radical Action

## CHAINS + BELTS

CCA5	Chain Assy Complete for Eliminator Pedals
BCA1	Belt Assy Complete for P2000 Eliminator Pedals
BCA250	Belt Assy Complete for P2050 Eliminator Pedals

## HI-HAT CLUTCHES

DCL300P	Drop Clutch, Rubber Washers, Lock Nut
SGC300P	Super Grip Clutch, Rubber Washers, Lock Nut
CL300P	Clutch, Triple-Lock, Rubber Washers, Lock Nut
CL300	Clutch, Triple-Lock, Felt Washers, Lock Nut
HCL79	Clutch, Standard, Felt Washers

## DRUM KEYS

KGT100	Gyro Tune Key w/Quick Release
K030	Hi-Tension Tuning Key
K080	Tuning Key
K180	Spin-Tight Key

## MUFFLER

OM1	External clamp-on muffler for snare drums and toms. By adjusting the pressure and position of the felt pad, excessive overtones can be precisely controlled or eliminated.
-----	--



## DRUM HEADS

Size	Model #	Size	Model #
8"	MFH08	14"	MFH14
10"	MFH10	16"	MFH16
12"	MFH12	20"	MFH20B
13"	MFH-13	22"	MFH22B

## BASS DRUM MUFFLER

BDMF	Bass Drum Muffler (Full Size)
------	-------------------------------

## JUNGLE GIG CONVERSION



JG16 - Pearl's Jungle Gig allows the conversion of a 16" Floor Tom to a Bass drum.

## PRACTICE PADS

BD10	BASS DRUM PEDAL TRAINING PADS The BD10 bass pad is perfect for practicing at home or on the road. The wide pad accommodates double pedals and is specially formulated for extremely low noise and a realistic feel. The universal-fit "hoop" accepts all brands of pedals and adjusts to compensate for different floor surfaces. The BD10 folds for compact transport.
------	--

**MASTERS MAPLE RESERVE** A CLASSIC FORMULA FOR SONIC GREATNESS

PAGES 20 - 21

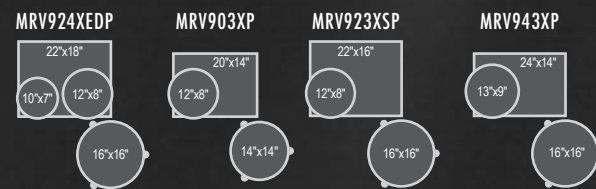

**MASTERS MAPLE COMPLETE** THE MASTERS SHELL COMES FULL CIRCLE

PAGES 22 - 23

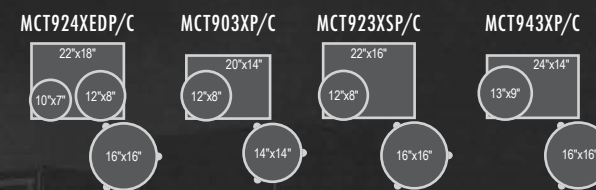

**SESSION STUDIO CLASSIC** THE ESSENTIAL SOUND OF STUDIO GROOVE

PAGES 24 - 25



**WOOD-FIBERGLASS** VINTAGE HYBRID, MODERN PERFORMANCE

PAGES 26 - 27

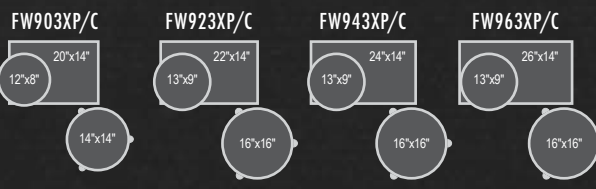

**CRYSTAL BEAT** THE ORIGINAL SEAMLESS ACRYLIC DRUM SHELL

PAGES 28 - 29

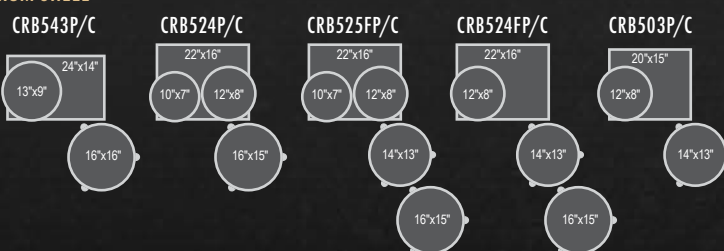

Individual components also available. For sizes, visit [www.pearldrums.com](http://www.pearldrums.com)

**DECADE MAPLE** A DRUM KIT 10 YEARS IN THE MAKING

PAGES 30 - 31

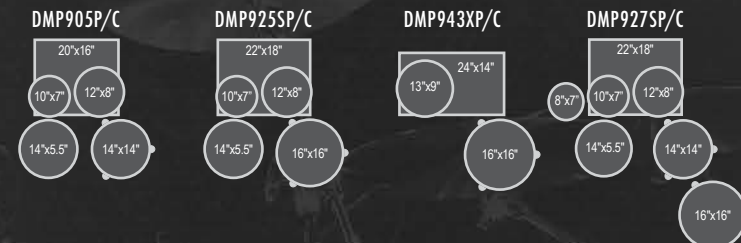

**EXPORT LACQUER** THE LEGENDS OF TOMORROW, PLAY EXPORT TODAY

PAGE 32

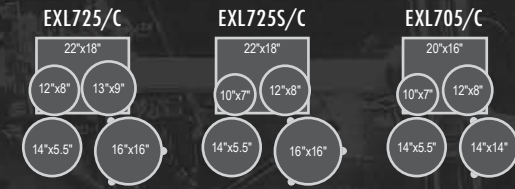

**EXPORT** THE BEST SELLING DRUM SET OF ALL TIME

PAGE 33

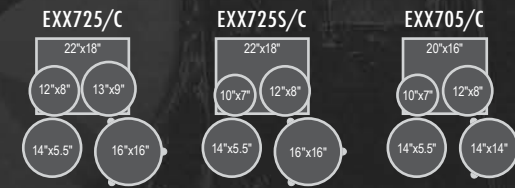

**MIDTOWN** BIG GIG, SMALL RIG, HUGE SOUND

PAGE 34

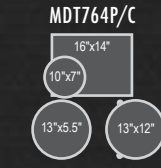

**ROADSHOW** IT'S YOUR TIME TO PLAY, START THE RIGHT WAY

PAGE 35

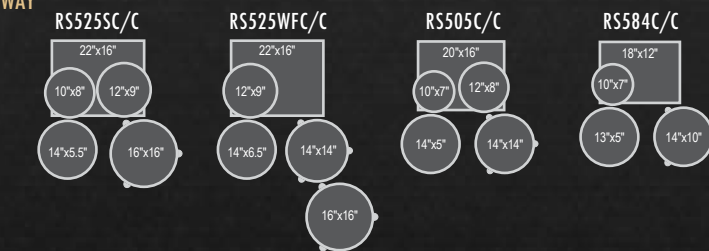



# Pearl CONFIGURATION + COLOR CHART

PAGES 12 - 15

## REFERENCE / REFERENCE PURE SONICALLY SELECT DRUM PERFORMANCE / UNRESTRICTED TONAL RESPONSE



#102 NATURAL MAPLE #103 PIANO BLACK #376 ULTRA BLUE FADE

RF

RF924XEDP/C  
RFP924XEDP/C

RF924XSP/C  
RFP924XSP/C

RF903XP/C  
RFP903XP/C

RF923XSP/C  
RFP923XSP/C

RF943XP/C  
RFP943XP/C



#102 NATURAL MAPLE #103 PIANO BLACK #377 SCARLET SPARKLE BURST

RFP



## REFERENCE / REFERENCE PURE SPECIAL ORDER COLORS



#100 WINE RED



#109 ARCTIC WHITE



#111 MATTE NATURAL



#126 EMERALD MIST



#128 VINTAGE SUNBURST



#142 ROOTBEER FADE



#143 TWILIGHT FADE



#148 EMERALD FADE



#151 PLATINUM MIST



#152 ANTIQUE GOLD



#153 SUNRISE FADE



#154 MIDNIGHT FADE



#155 SCARLET FADE



#197 RHYTHM BLUE



#302 INCA GOLD BURST



#329 BURNISHED BRONZE SPARKLE



#330 IVORY PEARL



#331 BLACK PEARL



#332 RED PEARL



#333 PURPLE METALLIC



#334 RED METALLIC



#335 BLACK CHERRY



#345 SATIN AUBURN



#355 ANTIQUE WALNUT



#356 TANGERINE DREAM



#368 BLACK SILVER BURST



#393 PURPLE CRAZE II



#342 VINTAGE TOBACCO BURST  
(Reference Pure Only)



WWW.PEARLDRUM.COM

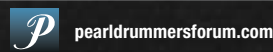
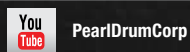
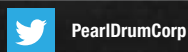
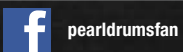

PGC2016